

2004

LG AIR CONDITIONERS

PRODUCT DATA



MPS Variable Multi Split SYSTEM

Free Joint, 50Hz, R410A

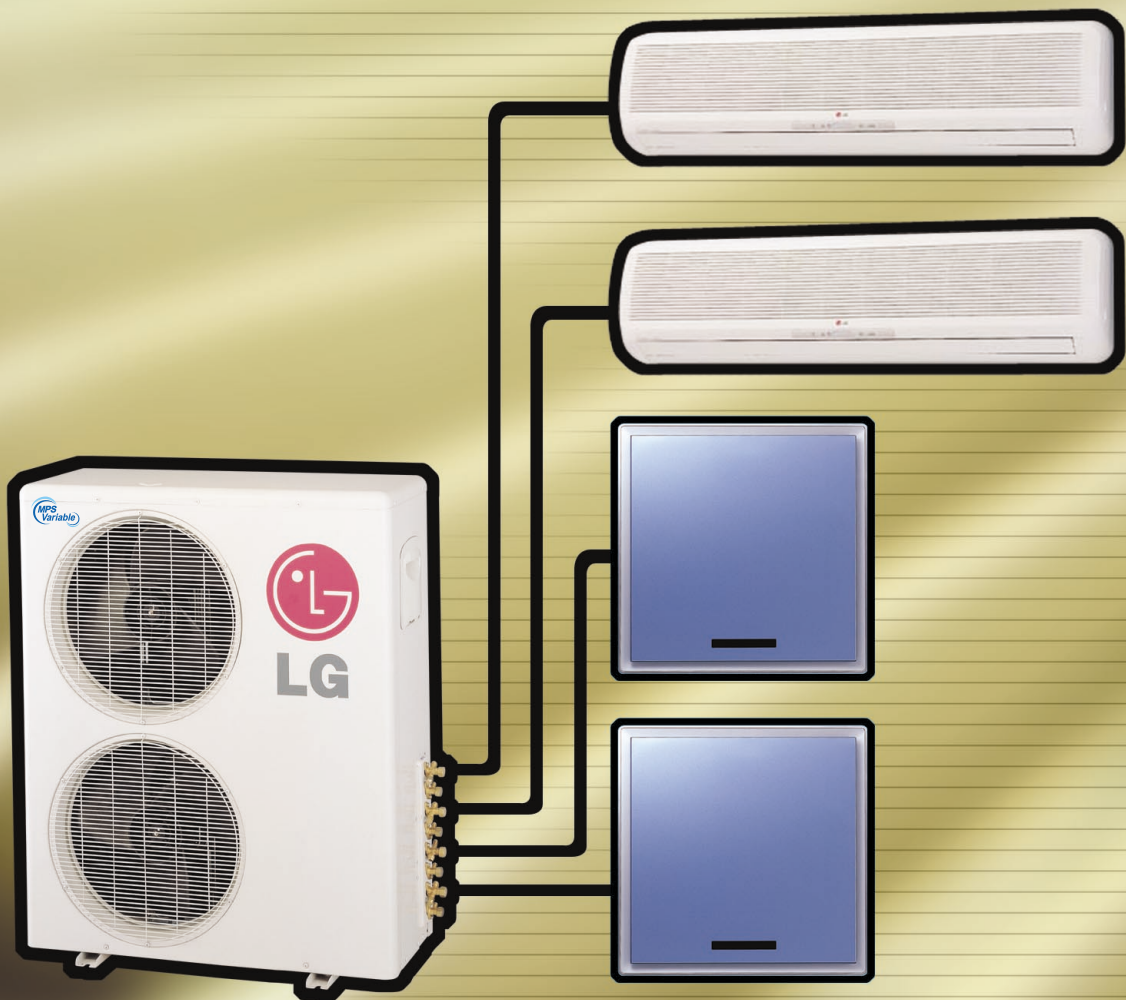



General Description

Thank you very much for your special patronage of LG air-conditioners.

A high-grade, high-quality, advanced individual air-conditioning system that is able to respond to expanding, more sophisticated housing environment needs.

LG Electronics Inc., which has been a top air conditioner maker for the three consecutive years, has developed "**MPS(Multi Power System) Variable Multi Split**" system that can efficiently control air-conditioning in a better way. Unlike traditional multi-type units, "**MPS Variable Multi Split**" is a next-generation multi type air-conditioner designed to be installed under any circumstance.

MPS control provides comfortable and convenient environment as small capacity compressor is operating continuously compared to conventional ON/OFF cycle compressor. A number of indoor units can be linked to an outdoor units so that each room can be individually air-conditioned.

This can be easily installed in a small space area, and is energy saving since the cooling of each room individually controlled.

A lot of information regarding the design and the installation of "**MPS Variable Multi Split**" system is included in this publication. We hope that with this information you would become an expert of the "**MPS Variable Multi Split**" system and be more comprehensive to the system.

LG Electronics Inc.
Air Conditioning Division



TABLE OF CONTENTS

<i>Table of contents</i>	<i>Page</i>
Part 1 Features.....	7
Part 2 MPS Variable Multi-Split system (R410A).....	11



Part 1

Features



Features & Benefit

MPS(Multi Power System) Variable Control : (Except A2UC146FA0,A2UH146FA0)



Big Energy Saving with MPS Variable Control

• Basic Principle of MPS Variable Control

MPS control provides comfortable and convenient environment as there are two compressors with 60&40% load sharing with on compressor of small capacity always working to maintain the set temperature conditions & meanwhile other compressor is at rest if the load is low whereas in conventional system the only compressor is working with ON/OFF cycles.

Conventional (On/Off Operation)

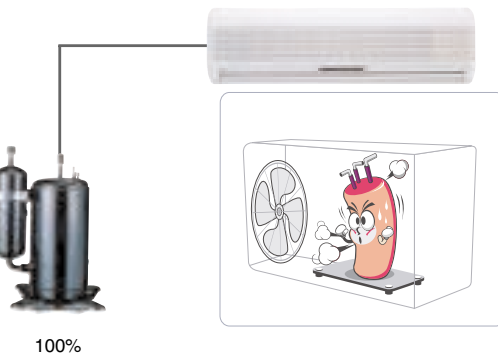

MPS Control

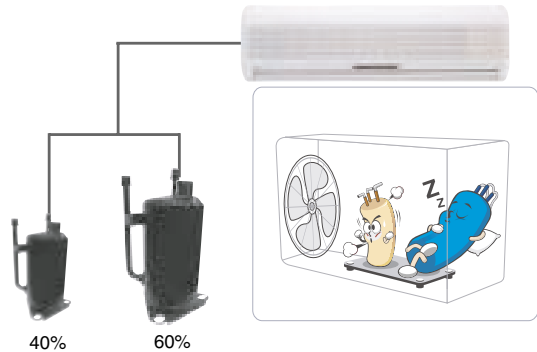

• Power Consumption Comparison

MPS Variable Multi system operates in one cycle with two compressors. Only one compressor or two compressors run together, according to the load conditions. With small load, only one compressor completes the cycle. It saves power consumption at low operation. This concept is explained in the picture below.

Conventional (On/Off Operation)

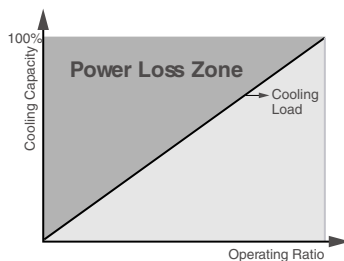

MPS

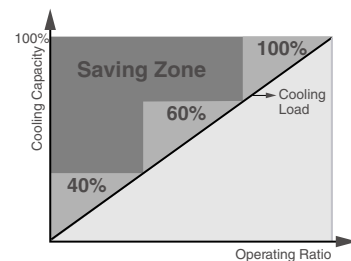

Max.
35%
Energy Saving

*Condition of trial : ISO5115

Features & Benefit

NANOplasma Air Purifying System

- It not only removes microscopic contaminants & dust, but it also removes house mites, pollen, and pet fur to help prevent allergic diseases like asthma. It provides odor free, dust free and allergy free air.

• Effect of carbon Nano Ball

Deodorizing efficiency: 8~10times compared to conventional carbon filter.

• What is Carbon Nano Ball?

Nano(1/1 Bil) ball structure, (200~500nm) consisted of carbon, is adopted as deodorizing material first in the world.

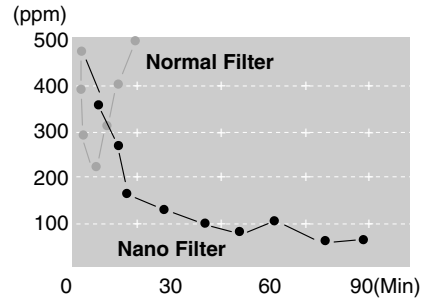

Odor Free! Dust Free! Allergy Free!

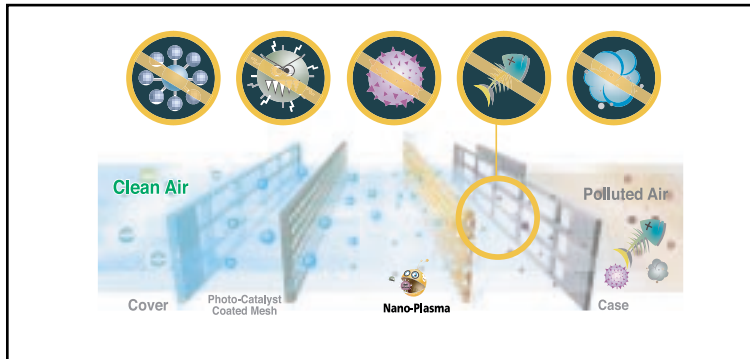

Triple Deodorizing Filter :

- Deodorizing efficiency
: 10% up compared to conventional Deodorizing Filter

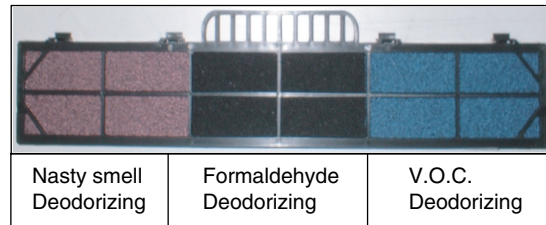

Composition of Triple Deodorizing Filter

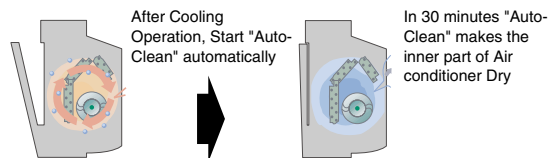

Auto Cleaning System :

- Auto Clean helps to remove odor and save clean-up time. After using air-conditioner, "Auto Clean" makes the inner part of Air conditioner dry in 30 min. It removes moisture and mould so you can enjoy odor-free air and save time to clean up.

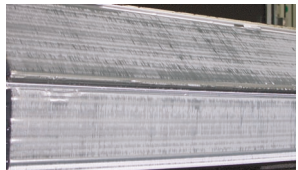

Before	After	Effect
		<p>Remove odor ! Restrain mildew ! Keep Performance ! (Durability) Save time to clean up.</p>



Features & Benefit

Ultra-Slim design(Depth 129mm)

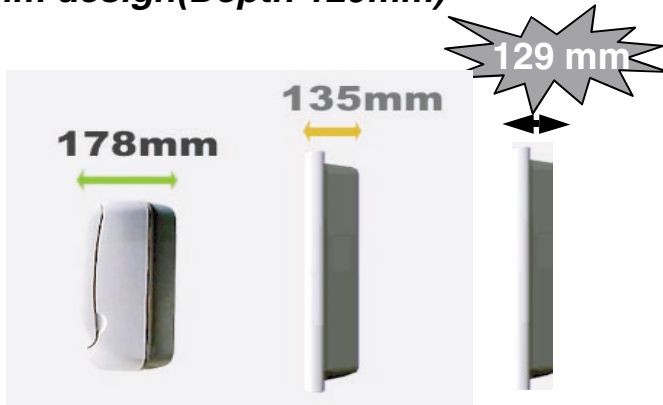

Thinnest Turbo Fan



3-Dimensional Cooling System

New Cube 3-Dimension cooling system of ART COOL has Indirect Cooling mode for sleep operation.

Being in sleep operation, cool air is discharged only right/left side!

Indirect cooling ensures you nice sleep.



Improved value of the 3-Dimensional Cooling

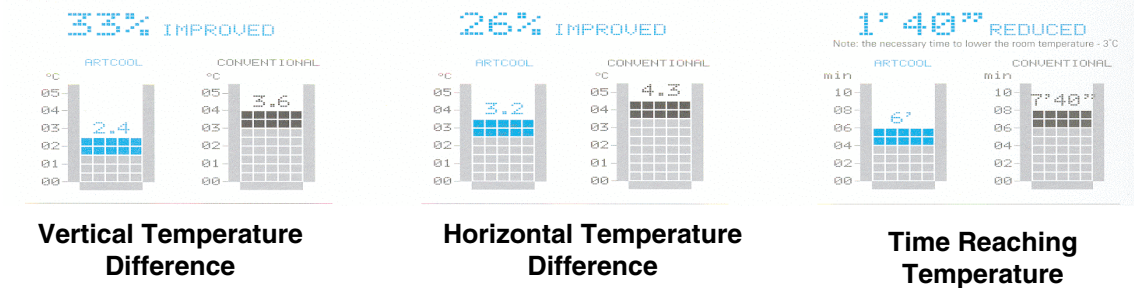

Air Flow Control (ART COOL)

- In normal mode, 3 Dimensional air flow cools air more fast and even widely
- The bottom-ward air flow provides you with speedy and powerful cooling
- When you sleep, Side air flow provides indirect and soft cooling

Normal



'Fast & Even Widely'

Jet Cool +

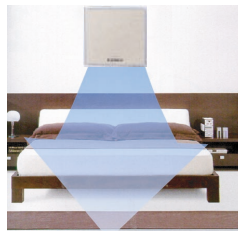

'Speedy & Powerful'

Sleep Mode



'Indirectly & Softly'

Features & Benefit

Environment Friendly Refrigerant :

- LG Air conditioners uses environment friendly refrigerant. Which don't do any harm to the environment.

Jet Cool:

- In this mode very quick and fast cooling is done. The unit will continue to supply high velocity air for 30 minutes, until the room temperature reaches 18°C. After 30 minutes, unit will supply air at the set fan speed whether indoor temperature has reached 18°C or not.

Self Diagnosis Function:

- This function provides diagnosis of the unit. Blinking of the operation LED of the indoor unit means there is some error.

Cooling, Heating & Fan Operation:

- LG multi air conditioners can provide cooling, heating & fan operation. In the cooling mode, it cools the air with an operation range of 18~30°C. In the heating mode, it heats the air with an operation range of 16~30°C. In the fan operation mode, only indoor fan will run at the selected speed, outdoor fan and compressor will be off.

LCD Wireless Remocon:

- It provides ease of control.

Auto Restart Operation :

- When there is electricity failure the unit shuts off. After resumption of the power, unit will start in the same mode as prior to the power failure. Memorized condition are on / off condition, operating mode (cooling/heating), set temperature and fan speed. The unit will memorize the above conditions and start with same memorized condition.

Hot Start Function :

- During starting of the unit in the heating mode it prevents cold air blow from the unit. It starts the indoor fan only after indoor unit pipe temperature reaches a preset value(28°C). When indoor unit pipe temperature has reached 28°C, then for initial 1 minute the indoor fan runs at low speed and after that at the set fan speed.

Defrost / Deicing :

- In the heating mode, it prevents the ice formation on the outdoor unit. Sensing the outdoor piping temperature, if it is lower than some preset value then the outdoor fan stops and compressor continues to run till a particular temperature is reached. Thereby preventing the frost on the outdoor coil. After reaching a particular high temperature outdoor fan again starts.

Time Delay Safety function:

-It delays restarting of the compressor by three minutes thereby preventing damage to the compressor .



Part 2

MPS Variable Multi-Split System

R410A, Cooling Only/Heat Pump

AMNC076LQL0	AMNC096AP*1	A2UC146FA0
AMNC096LQL0	AMNC126AP*1	A2UC186FA0
AMNC126LRL0		A3UC216FA0
AMNC186LTL0		A4UC306FA0
AMNC246LTL0		

AMNH076LQL0	AMNH096AP*1	A2UH146FA0
AMNH096LQL0	AMNH126AP*1	A2UH186FA0
AMNH126LRL0		A3UH216FA0
AMNH186LTL0		A4UH306FA0
AMNH246LTL0		

1. Power Supply	12
2. Model Number Nomenclature	13
3. Outline of System	14
4. List of Functions	16
5. Specifications	17
6. Combination Table	21
7. Dimensional Drawings	27
8. Wiring Diagrams.....	33
9. Piping Diagrams.....	43
10. Capacity Tables	49
11. Operation Limit.....	64
12. Air Velocity and Temperature Distributions(Reference Data)	65
13. Sound Levels	66
14. Installation.....	69
15. Function of Remote Controller	76



1. Power Supply

Type	Outdoor Unit	Power Supply
Cooling Only	A2UC146FA0 A2UC186FA0 A3UC216FA0 A4UC306FA0	1Ø, 220~240V, 50Hz
Heat Pump	A2UH146FA0 A2UH186FA0 A3UH216FA0 A4UH306FA0	

Note : Power Supply Intake ; Outdoor Unit Only

External wiring procedure

- The power supply is needed only to the outdoor unit. The power supply to the indoor unit is conducted through the transmission wiring. Therefore, the power supply can be given at just one place. It will contribute to simplify the work procedure and to save cost.

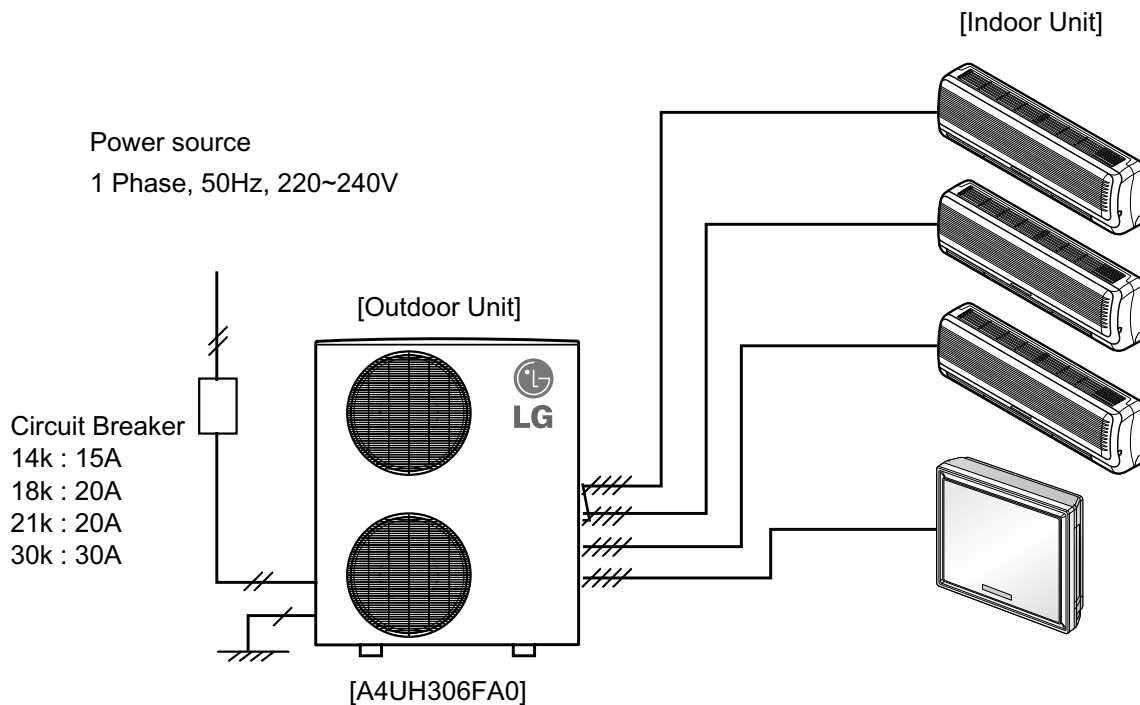

2. Model Number Nomenclature

2.1 Indoor Units

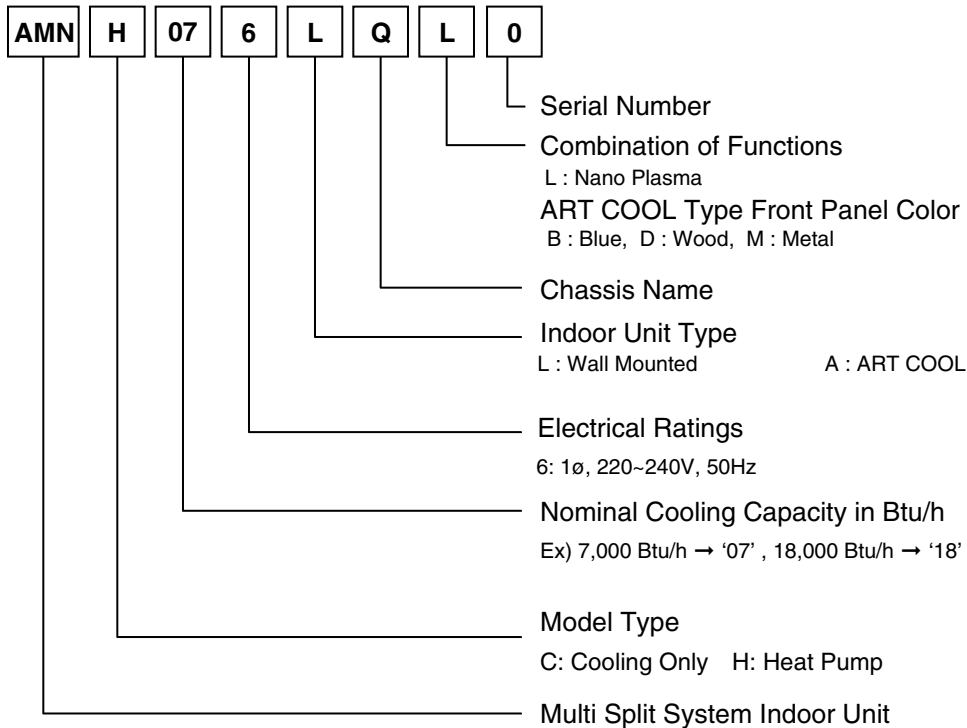

2.2 Outdoor Units

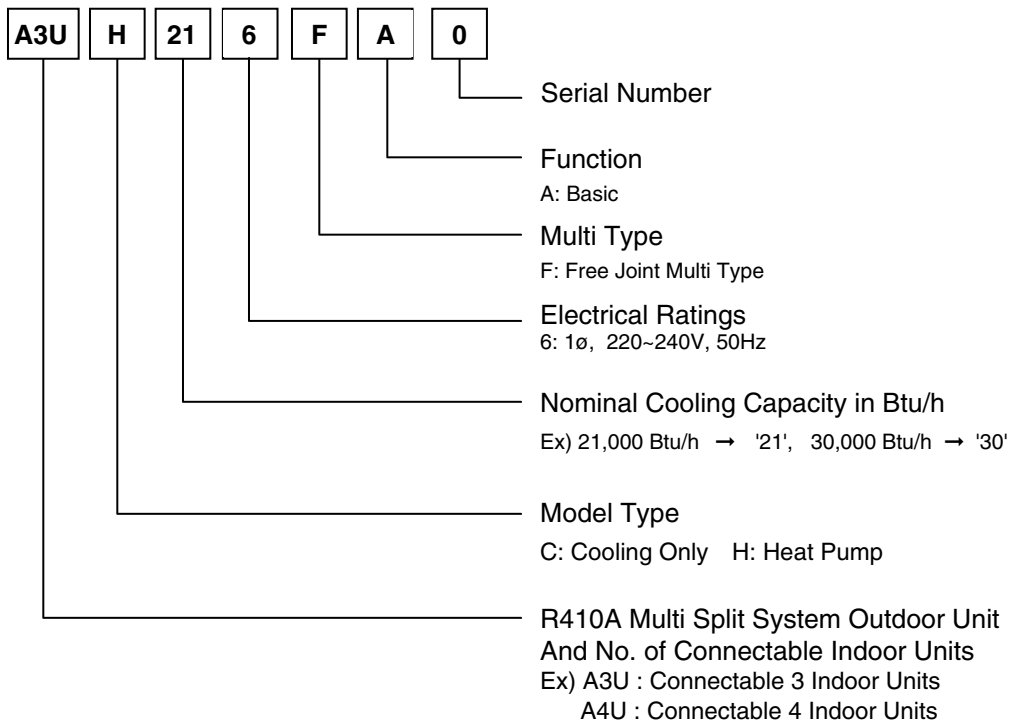



3. Outline of System

The system has number of indoor units attached to an outdoor unit which saves energy while in operation. This system can be installed in small space and cooling can be controlled in each room individually.

3.1 Example of System

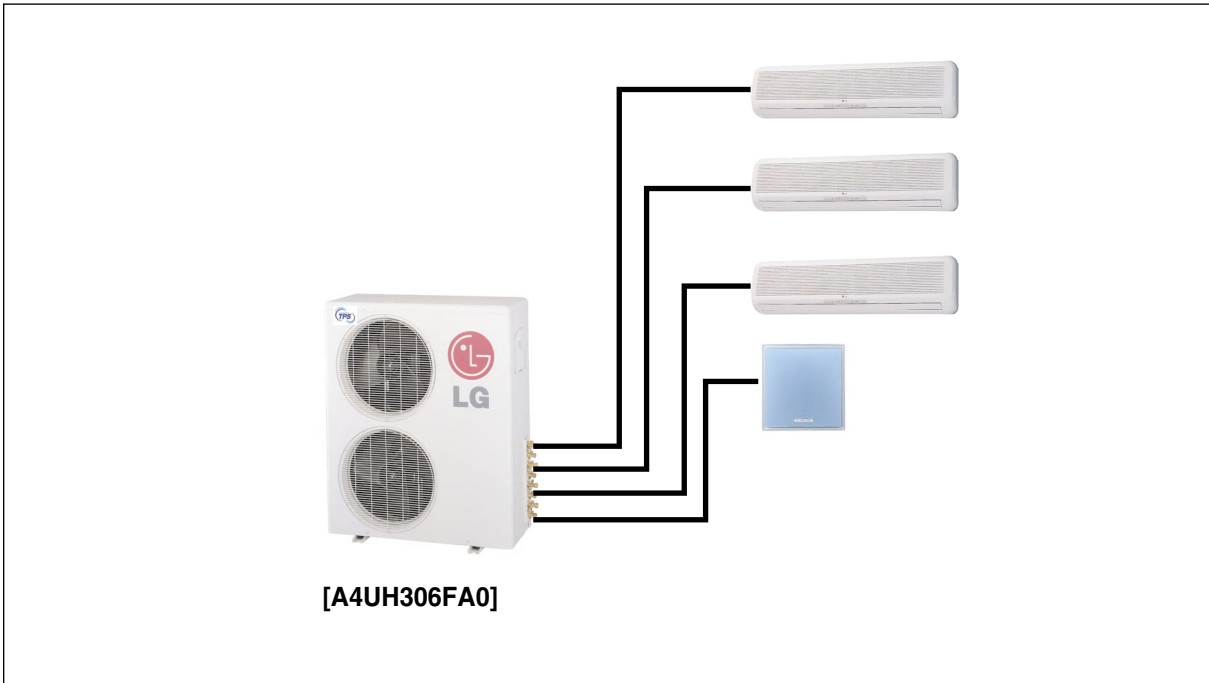

3.2 Combination of Indoor and Outdoor Unit

Model Type	Indoor Units			Outdoor Unit			
	Capacity			A2UC146FA0 A2UH146FA0	A2UC186FA0 A2UH186FA0	A3UC216FA0 A3UH216FA0	A4UC306FA0 A4UH306FA0
	Index	kW	Btu/h	No. of Connectable Indoor Units			
				2	2	3	4
Wall Mounted	7	2.1	7000	○	○	○	○
	9	2.6	9000	-	○	○	○
	12	3.5	12000	-	○	○	○
	18	5.3	18000	-	-	-	○
	24	7.0	24000	-	-	-	○
ART COOL	9	2.6	9000	-	○	○	○
	12	3.5	12000	-	○	○	○

3. Outline of System

3.3 External Appearance of Indoor Units

Wall Mounted

AMNC076LQL0 AMNH076LQL0
AMNC096LQL0 AMNH096LQL0
AMNC126LRL0 AMNH126LRL0
AMNC186LTLO AMNH186LTLO
AMNC246LTLO AMNH246LTLO



ART COOL

AMNC096AP*1 AMNH096AP*1
AMNC126AP*1 AMNH126AP*1



* : Front Panel Color
B : Blue
D : Wood
M : Metal



4. List of Functions

Features	Model	AMNC-LQ/LR/LT	AMNC-AP	AMNH-LQ/LR/LT	AMNH-AP
Airflow Direction Control(Left & Right)		Manual	Manual	Manual	Manual
Airflow Direction Control(Up & Down)		Automatic	Automatic	Automatic	Automatic
Airflow Outlet		1	3	1	3
Airflow Steps(Fan / Cool / Heat)		3/4/3	3/4/3	3/4/3	3/4/3
Auto Changeover(Operation)		-	-	-	-
Auto Cleaning		-	O	-	O
Auto Restart Operation		O	O	O	O
Central Control		Accessory	Accessory	Accessory	Accessory
CHAOS Wind(Auto Wind)		O	O	O	O
Child Lock Function		-	-	-	-
Cooling & Heating Fan Operation		O(not heating)	O(not heating)	O	O
Deice Control		-	-	O	O
Deodorizing Filter		O(Triple)	-	O(Triple)	-
Drain Pump		-	-	-	-
E.S.P Control		-	-	-	-
Forced Operation		O	O	O	O
Group Control		-	-	-	-
High Ceiling Operation		-	-	-	-
Hot Start Function		-	-	O	O
Jet Cool		O	O	O	O
Nano Plasma Air Purifying Filter		O	O	O	O
Plasma Heat Exchanger		-	-	-	-
Prefilter(Washable / Anti-fungus)		O	O	O	O
Self Diagnosis Function		O	O	O	O
Sleep Mode Operation		O	O	O	O
Soft Dry Operation		O	O	O	O
Soft Start Function		-	-	-	-
Test Function		O	O	O	O
Time Delay Safety Function		O	O	O	O
Timer(24 Hour, On/Off)		O	O	O	O
Timer(Weekly, On/Off)		-	-	-	-
Two Thermistor Control		-	-	-	-
Wired LCD Remote Control		-	-	-	-
Wireless LCD Remote Control		O	O	O	O
Zero Standby Power		-	-	-	-
Zone Control		-	-	-	-

Notes :

O : Basic

Optional : Factory-Installed

Accessory : Field-Installed

- : Not available on this system

5. Specifications

5.1 Indoor Units

Cooling Only

Indoor Unit Type			Wall Mounted				
Model			AMNC076LQL0	AMNC096LQL0	AMNC126LRL0	AMNC186LTL0	AMNC246LTL0
Nominal Cooling Capacity ★	kcal/hr(W)		1764(2051)	2267(2638)	3024(3515)	4536(5275)	5795(6740)
	Btu/hr		7000	9000	12000	18000	23000
Nominal Heating Capacity ★	kcal/hr(W)		-	-	-	-	-
	Btu/hr		-	-	-	-	-
Air Circulation	H/M/L	CMM(CFM)	5.5(194)	6.0(212)	9.0(318)	13(459)	14(495)
Setting temperature range		°C	18-30 / -	18-30 / -	18-30 / -	18-30 / -	18-30 / -
Fan motor	Output	W	8.4	8.4	14.4	23	28
	Model		IC-8415LG62A	IC-8415LG62A	IC-8420LG48A	AMR-023E2	AMR-023E5
	No. of Poles		4	4	4	4	6
	Input	W	25	25	37	34	63
	Running Current	A	0.11	0.11	0.16	0.15	0.28
	Capacitor	µF/Vac	0.9 / 400	0.9 / 400	0.9 / 400	2.0 / 370	2.0 / 370
	Fan	Type		Cross Flow Fan	Cross Flow Fan	Cross Flow Fan	Cross Flow Fan
Fan RPM	No. Used / Diameter	EA/inch(mm)	1/3.43(87)	1/3.43(87)	1/3.43(87)	1/3.74(95)	1/3.74(95)
	Cooling(H/M/L)	rpm	1080 / 970 / 880	1170 / 1100 / 1020	1290 / 1200 / 1120	1140 / 1040 / 940	1260 / 1140 / 1000
Noise Level(Sound Press.1m)	Heating(H/M/L)	rpm	-	-	-	-	-
	H/M/L	dBA	34/31/28	35/32/30	38/36/34	42/38/35	46/40/38
Temperature controller			Thermistor	Thermistor	Thermistor	Thermistor	Thermistor
Coil	Tube Size (OD)	inch(mm)	0.197(5.0)	0.197(5.0)	0.197(5.0)	0.276(7.0)	0.276(7.0)
	Fins per inch		19	19	20	20	20
	No. of Rows & Column		2R,10C	2R,10C	2R,12C	2R,13C	2R,13C
Dehumidification Rate		l/h	0.9	1.0	1.2	2.3	3.0
Dimensions (W*H*D)		inch(mm)	32.4*10.2*6.1(820*260*155)	32.4*10.2*6.1(820*260*155)	35.4*11.2*6.1(900*285*156)	42.9*12.4*6.8(1090*314*172)	42.9*12.4*6.8(1090*314*172)
Net Weight		kg(lbs)	7(15.4)	7(15.4)	9(19.8)	12(26.5)	12(26.5)
Piping Connection	Liquid	inch(mm)	1/4 (6.35)	1/4 (6.35)	1/4 (6.35)	1/4 (6.35)	1/4 (6.35)
	Gas	inch(mm)	3/8 (9.52)	3/8 (9.52)	3/8 (9.52)	1/2 (12.7)	1/2 (12.7)
	Drain hose (ID Ø)	mm	20	20	20	20	20
Packing Dimension (W*H*D)		inch(mm)	35.4*9.2*13.4(900*233*340)	35.4*9.2*13.4(900*233*340)	38.4*9.2*14.6(976*233*372)	45.9*10.0*15.3(1165*255*388)	45.9*10.0*15.3(1165*255*388)
Stuffing Quantity	Without S/Parts	20/40ft	354/774 (360/780)	354/774 (360/780)	338/714 (340/720)	264/536 (270/540)	264/536 (270/540)

Indoor Unit Type			ART COOL	
Model			AMNC096AP*1	AMNC126AP*1
Nominal Cooling Capacity ★	kcal/hr(W)		2267(2638)	3024(3515)
	Btu/hr		9000	12000
Nominal Heating Capacity ★	kcal/hr(W)		-	-
	Btu/hr		-	-
Air Circulation	H/M/L	CMM(CFM)	7.5(264)	8.5(300)
Setting temperature range		°C	18-30 / -	18-30 / -
Fan motor	Output	W	-	-
	Model		SIC-39CV-D828-1	SIC-39CV-D828-1
	No. of Poles		8	8
	Input	W	18	18
	Running Current	A	0.08	0.08
	Capacitor	µF/Vac	-	-
	Fan	Type		Turbo Fan
Fan RPM	No. Used / Diameter	EA/inch(mm)	1/16.9(430)	1/16.9(430)
	Cooling(H/M/L)	rpm	(510/350/290)	(560/460/360)
Noise Level(Sound Press.1m)	Heating(H/M/L)	rpm	-	-
	H/M/L	dBA	37/31/27	43/39/31
Temperature controller			Thermistor	Thermistor
Coil	Tube Size (OD)	inch(mm)	0.197(5.0)	0.197(5.0)
	Fins per inch		20	20
	No. of Rows & Column		2R,20C	2R,20C
Dehumidification Rate		l/h	1.1	1.4
Dimensions (W*H*D)		inch(mm)	22.4*22.4*5.1 (570*568*129)	22.4*22.4*5.1 (570*568*129)
Net Weight		kg(lbs)	9(19.84)	9(19.84)
Piping Connection	Liquid	inch(mm)	1/4 (6.35)	1/4 (6.35)
	Gas	inch(mm)	3/8 (9.52)	3/8 (9.52)
	Drain hose (ID Ø)	mm	20	20
Packing Dimension (W*H*D)		inch(mm)	26.2*25.7*9.1(665*653*231)	26.2*25.7*9.1(665*653*231)
Stuffing Quantity	Without S/Parts	20/40ft	237/534 (239/539)	237/534 (239/539)
Front Panel Color		*** Position	M: Metal, B: Blue, D: Wood	

Note : 1. ★ See the page "Combination Table"

2. Due to our policy of innovation some specifications may be changed without notification.



5. Specifications

Heat Pump

Indoor Unit Type			Wall Mounted					
Model			AMNH076LQLO	AMNH096LQLO	AMNH126LRL0	AMNH186LTLO	AMNH246LTLO	
Nominal Cooling Capacity ★	kcal/hr(W)		1764(2051)	2267(2638)	3024(3515)	4536(5275)	5796(6740)	
	Btu/hr		7000	9000	12000	18000	23000	
Nominal Heating Capacity ★	kcal/hr(W)		2016(2343)	2520(2929)	3326(3867)	4990(5803)	6426(7472)	
	Btu/hr		8000	10000	13200	19800	25500	
Air Circulation	H/M/L	CMM(CFM)	5.5(194)	6.0(212)	9.0(318)	13(459)	14(495)	
Setting temperature range			°C	18-30 / 16-30	18-30 / 16-30	18-30 / 16-30	18-30 / 16-30	
Fan motor	Output	W	8.4	8.4	14.4	23	28	
	Model		IC-8415LG62A	IC-8415LG62A	IC-8420LG48A	AMR-023E2	AMR-023E5	
	No. of Poles		4	4	4	4	4	
	Input	W	25	25	37	34	63	
	Running Current	A	0.11	0.11	0.16	0.15	0.28	
	Capacitor	µF/Vac	0.9 / 400	0.9 / 400	0.9 / 400	2.0 / 370	2.0 / 370	
	Fan	Type		Cross Flow Fan	Cross Flow Fan	Cross Flow Fan	Cross Flow Fan	Cross Flow Fan
Fan RPM	No. Used / Diameter	EA/inch(mm)	1/3.43(87)	1/3.43(87)	1/3.43(87)	1/3.74(95)	1/3.74(95)	
	Cooling(H/M/L)	rpm	1080 / 970 / 880	1170 / 1100 / 1020	1290 / 1200 / 1120	1140 / 1040 / 940	1260 / 1140 / 1000	
Noise Level(Sound Press.1m)	Heating(H/M/L)	rpm	1080 / 970 / 880	1170 / 1100 / 1020	1290 / 1200 / 1120	1140 / 1040 / 940	1260 / 1140 / 1000	
	H/M/L	dBA	34/31/28	35/32/30	38/36/34	42/38/35	46/40/38	
Temperature controller			Thermistor	Thermistor	Thermistor	Thermistor	Thermistor	
Coil	Tube Size (OD)	inch(mm)	0.197(5.0)	0.197(5.0)	0.197(5.0)	0.276(7.0)	0.276(7.0)	
	Fins per inch		19	19	20	20	20	
	No. of Rows & Column		2R,10C	2R,10C	2R,12C	2R,13C	2R,13C	
Dehumidification Rate			l/h	0.9	1.0	1.2	2.3	
Dimensions (W*H*D)			inch(mm)	32.4*10.2*6.1(820*260*155)	32.4*10.2*6.1(820*260*155)	35.4*11.2*6.1(900*285*156)	42.9*12.4*6.8(1090*314*172)	42.9*12.4*6.8(1090*314*172)
Net Weight			kg(lbs)	7(15.4)	7(15.4)	9(19.8)	12(26.5)	12(26.5)
Piping Connection	Liquid	inch(mm)	1/4 (6.35)	1/4 (6.35)	1/4 (6.35)	1/4 (6.35)	1/4 (6.35)	
	Gas	inch(mm)	3/8 (9.52)	3/8 (9.52)	3/8 (9.52)	1/2 (12.7)	1/2 (12.7)	
	Drain hose (ID Ø)	mm	20	20	20	20	20	
Packing Dimension (W*H*D)			inch(mm)	35.4*9.2*13.4(900*233*340)	35.4*9.2*13.4(900*233*340)	38.4*9.2*14.6(976*233*372)	45.9*10.0*15.3(1165*255*388)	45.9*10.0*15.3(1165*255*388)
Stuffing Quantity	Without S/Parts		20/40ft	354/774 (360/780)	354/774 (360/780)	338/714 (340/720)	264/536 (270/540)	264/536 (270/540)

Indoor Unit Type			ART COOL	
Model			AMNH096AP*1	AMNH126AP*1
Nominal Cooling Capacity ★	kcal/hr(W)		2267(2638)	3024(3515)
	Btu/hr		9000	12000
Nominal Heating Capacity ★	kcal/hr(W)		2520(2929)	3326(3867)
	Btu/hr		10000	13200
Air Circulation	H/M/L	CMM(CFM)	7.5(264)	8.5(300)
Setting temperature range			°C	18-30 / 16-30
Fan motor	Output	W	-	-
	Model		SIC-39CV-D828-1	SIC-39CV-D828-1
	No. of Poles		8	8
	Input	W	18	18
	Running Current	A	0.08	0.08
	Capacitor	µF/Vac	-	-
	Fan	Type		Turbo Fan
Fan RPM	No. Used / Diameter	EA/inch(mm)	1/16.9(430)	1/16.9(430)
	Cooling(H/M/L)	rpm	(510/350/290)	(560/460/360)
Noise Level(Sound Press.1m)	Heating(H/M/L)	rpm	(510/350/290)	(560/460/360)
	H/M/L	dBA	37/31/27	43/39/31
Temperature controller			Thermistor	Thermistor
Coil	Tube Size (OD)	inch(mm)	0.197(5.0)	0.197(5.0)
	Fins per inch		20	20
	No. of Rows & Column		2R,20C	2R,20C
Dehumidification Rate			l/h	1.1
Dimensions (W*H*D)			inch(mm)	22.4*22.4*5.1 (570*568*129)
Net Weight			kg(lbs)	9(19.84)
Piping Connection	Liquid	inch(mm)	1/4 (6.35)	1/4 (6.35)
	Gas	inch(mm)	3/8 (9.52)	3/8 (9.52)
	Drain hose (ID Ø)	mm	20	20
Packing Dimension (W*H*D)			inch(mm)	26.2*25.7*9.1(665*653*231)
Stuffing Quantity	Without S/Parts		20/40ft	237/534 (239/539)
Front Panel Color	*** Position			M: Metal, B: Blue, D: Wood

Note : 1. ★ See the page "Combination Table"

2. Due to our policy of innovation some specifications may be changed without notification.

5. Specifications

5.2 Outdoor Units

Cooling Only

Model		A2UC146FA0	A2UC186FA0	A3UC216FA0	A4UC306FA0	
Cooling Capacity ★	kcal/hr	2268~3780	1764~4536	2016~5292	2268~7560	
	W	2636~4394	2051~5275	2345~6154	2638~8787	
	Btu/hr	9000~15000	7000~18000	8000~21000	9000~30000	
Heating Capacity ★	kcal/hr	-	-	-	-	
	W	-	-	-	-	
	Btu/hr	-	-	-	-	
Input ★	Cooling/Heating	W	1300~1400 / -	780~1900 / -	880~2100 / -	1100~3250 / -
Running Current ★	Cooling/Heating	A	6.1~6.7 / -	3.5~8.5 / -	4.0~9.4 / -	4.8~15 / -
Starting Current	Cooling/Heating	A	-	-	-	-
Power Supply	∅, V, Hz	1,220-240,50	1,220-240,50	1,220-240,50	1,220-240,50	
Power Factor	%	-	-	-	-	
Compressor A	Locked Rotor Amp.	A	37	24	25.2	35.5
	Type		Rotary	Rotary	Rotary	Rotary
	Quantity	No	1	1	1	1
	Model		GJ176PAA	5KS140DAD21	5KS150EAB21	5KS225DKSM681
	Maker		LG. Electric	Matsushita Electric	Matsushita Electric	Matsushita Electric
	Capacity	kcal/hr(Btu/hr)	3654(14500) at 50Hz & 240V	2932(11635) at 50Hz & 240V	3130(12420) at 50Hz & 240V	4901(19450) at 50Hz & 240V
	Motor Type		Permanent split capacitor	Permanent split capacitor	Permanent split capacitor	Permanent split capacitor
	Motor Input	W	1526	1290	1290	2175
	Oil Type		FVS68D(PVE)	FV50S(PVE)	FV50S(PVE)	FV50S(PVE)
	Oil Charge	cc	500	670	670	670
	O.L.P Type(model name)		Internal	MRA98781-9090	MRA99150-9090	Internal
	Compressor B	Locked Rotor Amp.	A	-	17.2	20.3
Type			-	Rotary	Rotary	Rotary
Quantity		No	-	1	1	1
Model			-	5PS102EAC21	5PS112EBB21	5KS150DKSM564
Maker			-	Matsushita Electric	Matsushita Electric	Matsushita Electric
Capacity		kcal/hr(Btu/hr)	-	2076(8240) at 50Hz & 240V	2253(8940) at 50Hz & 240V	3181(12625) at 50Hz & 240V
Motor Type			-	Permanent split capacitor	Permanent split capacitor	Permanent split capacitor
Motor Input		W	-	865	975	1320
Oil Type			-	FV50S(PVE)	FV50S(PVE)	FV50S(PVE)
Oil Charge		cc	-	350	350	670
O.L.P Type(model name)			-	MRA99901-9090	MRA99282-9090	MRA99150-9090
Refrigerant		Charge	g(oz), type	1050(37.04) at 7.5m	1350(47.62) at 7.5m	1500(52.91) at 7.5m
	Type		R410A	R410A	R410A	R410A
	Control		Capillary Tube	L.E.V	L.E.V	L.E.V
Coil	Tube Size (OD)	inch(mm)	0.276(7.0)	0.276(7.0)	0.276(7.0)	0.276(7.0)
	Fins per inch		18	18	18	18
	No. of Rows & Column/No.		2R,24C	2R,28C	2R,28C	2R,48C
Fan Motor	Output	W	27	67.2	67.2	41
	Model		AMR036E1	IC-28640LG28J	IC-28640LG28J	IC-9625LGSY
	No. of Poles		4	6	6	6
	Input	W	79	120	120	80
	Running Current	A	0.35	1.4	1.4	0.35
	Capacitor	µF/Vac	1.5/400	6/370	6/370	2/370
Fan	Type		Propeller	Propeller	Propeller	Propeller
	No. Used / Diameter	EA/inch(mm)	1/15.25(387.6)	1/18.1(460)	1/18.1(460)	2/15.7(400)
	Discharge	Side / Top	Side Discharge	Side Discharge	Side Discharge	Side Discharge
	Speed	rpm	680	850	850	880 / 710
Air Circulation		CMM(CFM)	40(1412)	53(1872)	53(1872)	63(2225)
Noise Level(Sound Press,1m)		dBA	52	53	53	54/51
Piping Connection	Liquid	inch(mm)	1/4(6.35)*2EA	1/4(6.35)*2EA	1/4(6.35)*3EA	1/4(6.35)*4EA
	Gas	inch(mm)	3/8(9.52)*2EA	3/8(9.52)*2EA	3/8(9.52)*3EA	3/8(9.52)*4EA
	Drain(ID ∅)	mm	-	-	-	-
Dimensions (W*H*D)	inch(mm)	31.5*21.8*10.3 (801 * 555 * 262)	34.3*25.8*12.6 (870*655*320)	34.3*25.8*12.6 (870*655*320)	34.3*41.7*12.6 (870*1060*320)	
Net Weight	kg(lbs)	48(106)	64(141)	64(141)	80(176)	
Power Supply Cable	No.* mm ²	3*2.1(Includes earth)	3*3.5(Includes earth)	3*3.5(Includes earth)	3*4.5(Includes earth)	
Interunit Cable	No.* mm ²	4*0.75(Includes earth)	4*0.75(Includes earth)	4*0.75(Includes earth)	4*0.75(Includes earth)	
Max. Interunit Piping Length	Total of Each Room	m	30	30	45	60
	For One Room	m	15	15	15	15
Max. Installation Height Difference	Indoor Unit-Outdoor Unit	m	7.5	7.5	7.5	7.5
	Indoor Unit-Indoor Unit	m	7.5	7.5	7.5	7.5
Packing Dimension (W*H*D)	inch(mm)	37.8*24.0*15.1 (960*610*384)	40.1*28.1*17.3 (1020*715*440)	40.1*28.1*17.3 (1020*715*440)	41.1*44.9*17.3 (1045*1140*440)	
Stuffing Quantity	With/Without) S/Parts	20/40ft	108/222 (108/222)	80/170(81/171)	80/170(81/171)	(51/111)

Notes: 1. Capacities are based on the following conditions:

Cooling: - Indoor Temperature 27°C(80.6°F) DB /19°C(66.2°F) WB
 - Outdoor Temperature 35°C(95°F) DB /24°C(75.2°F) WB
 - Interconnecting Piping Length 7.5m
 - Level Difference of Zero.

Heating: - Indoor Temperature 20°C(68°F) DB / 15°C(59°F) WB
 - Outdoor Temperature 7°C(44.6°F) DB / 6°C(42.8°F) WB
 - Interconnecting Piping Length 7.5 m
 - Level Difference of Zero.

2. Capacities are Net Capacities.

3. ★ : See the page "Combination Table"

4. Due to our policy of innovation some specifications may be changed without notification.



5. Specifications

Heat Pump

Model			A2UH146FA0	A2UH186FA0	A3UH216FA0	A4UH306FA0
Cooling Capacity ★		kcal/hr	2369~3629	1764~4536	2016~5292	2268~7560
		W	2755~4220	2051~5275	2345~6154	2638~8787
		Btu/hr	9400~14400	7000~18000	8000~21000	9000~30000
Heating Capacity ★		kcal/hr	2520~3679	2268~4990	2268~5292	2520~8317
		W	2931~4279	2638~5803	2638~6154	2931~9666
		Btu/hr	10000~14600	9000~19800	9000~21000	10000~33000
Input ★	Cooling/Heating	W	1350~1450/1300~1500	780~1900 / 1200~1900	880~2100 / 1350~2200	1100~3250 / 1310~3360
Running Current ★	Cooling/Heating	A	6.1~6.6/6.0~7.0	3.5~8.5 / 5.5~8.5	4.0~9.4 / 6.0~9.8	4.8~15 / 6.0~15.5
Starting Current	Cooling/Heating	A	-	-	-	-
Power Supply		∅,V,Hz	1,220-240,50	1,220-240,50	1,220-240,50	1,220-240,50
Power Factor		%	-	-	-	-
Compressor A	Locked Rotor Amp.	A	37	24	25.2	35.5
	Type		Rotary	Rotary	Rotary	Rotary
	Quantity	No	1	1	1	1
	Model		GJ176PAA	5KS140DAD21	5KS150EAB21	5KS225DKSM681
	Maker		LG. Electric	Matsushita Electric	Matsushita Electric	Matsushita Electric
	Capacity	kcal/hr(Btu/hr)	3654(14500) at 50Hz & 240V	2932(11635) at 50Hz & 240V	3130(12420) at 50Hz & 240V	4901(19450) at 50Hz & 240V
	Motor Type		Permanent split capacitor	Permanent split capacitor	Permanent split capacitor	Permanent split capacitor
	Motor Input	W	1526	1290	1290	2175
	Oil Type		FVS68D(PVE)	FV50S(PVE)	FV50S(PVE)	FV50S(PVE)
	Oil Charge	cc	500	670	670	670
O.L.P Type(model name)		Internal	MRA98781-9090	MRA99150-9090	Internal	
Compressor B	Locked Rotor Amp.	A	-	17.2	20.3	25.2
	Type		-	Rotary	Rotary	Rotary
	Quantity	No	-	1	1	1
	Model		-	5PS102EAC21	5PS112EBB21	5KS150DKSM564
	Maker		-	Matsushita Electric	Matsushita Electric	Matsushita Electric
	Capacity	kcal/hr(Btu/hr)	-	2076(8240) at 50Hz & 240V	2253(8940) at 50Hz & 240V	3181(12625) at 50Hz & 240V
	Motor Type		-	Permanent split capacitor	Permanent split capacitor	Permanent split capacitor
	Motor Input	W	-	865	975	1320
	Oil Type		-	FV50S(PVE)	FV50S(PVE)	FV50S(PVE)
	Oil Charge	cc	-	350	350	670
O.L.P Type(model name)		-	MRA99901-9090	MRA99282-9090	MRA99150-9090	
Refrigerant	Charge	g(oz), type	1100(38.8) at 7.5m	1350(47.62) at 7.5m	1500(52.91) at 7.5m	2500(88.2) at 7.5m
	Type		R410A	R410A	R410A	R-410A
	Control		Capillary Tube	L.E.V	L.E.V	L.E.V
Coil	Tube Size (OD)	inch(mm)	0.276(7.0)	0.276(7.0)	0.276(7.0)	0.276(7.0)
	Fins per inch		18	18	18	18
	No. of Rows & Column/No.		2R,24C	2R,28C	2R,28C	2R,48C
Fan Motor	Output	W	27	67.2	67.2	41
	Model		AMR036E1	IC-28640LG28J	IC-28640LG28J	IC-9625LGSY
	No. of Poles		4	6	6	6
	Input	W	79	120	120	80
	Running Current	A	0.35	1.4	1.4	0.35
Capacitor	µF/Vac	1.5/400	6/370	6/370	2/370	
Fan	Type		Propeller	Propeller	Propeller	Propeller
	No. Used / Diameter	EA/inch(mm)	1/15.25(387.6)	1/18.1(460)	1/18.1(460)	2/15.7(400)
	Discharge	Side / Top	Side Discharge	Side Discharge	Side Discharge	Side Discharge
	Speed	rpm	680	850	850	880 / 710
Air Circulation		CMM(CFM)	40(1412)	53(1872)	53(1872)	63(2225)
Noise Level(Sound Press,1m)		dB(A)	52	53	53	54/51
Piping Connection	Liquid	inch(mm)	1/4(6.35)*2EA	1/4(6.35)*2EA	1/4(6.35)*3EA	1/4(6.35)*4EA
	Gas	inch(mm)	3/8(9.52)*2EA	3/8(9.52)*2EA	3/8(9.52)*3EA	3/8(9.52)*4EA
	Drain(ID ∅)	mm	-	-	-	32
Dimensions (W*H*D)	inch(mm)	31.5*21.8*10.3 (801 * 555 * 262)	34.3*25.8*12.6 (870*655*320)	34.3*25.8*12.6 (870*655*320)	34.3*41.7*12.6 (870*1060*320)	
Net Weight	kg(lbs)	48(106)	64(141)	64(141)	80(176)	
Power Supply Cable	No. * mm ²	3*2.1(Includes earth)	3*3.5(Includes earth)	3*3.5(Includes earth)	3*4.5(Includes earth)	
Interunit Cable	No. * mm ²	4*0.75(Includes earth)	4*0.75(Includes earth)	4*0.75(Includes earth)	4*0.75(Includes earth)	
Max. Interunit Piping Length	Total of Each Room	m	30	30	45	60
	For One Room	m	15	15	15	15
Max. Installation Height Difference	Indoor Unit-Outdoor Unit	m	7.5	7.5	7.5	7.5
	Indoor Unit-Indoor Unit	m	7.5	7.5	7.5	7.5
Packing Dimension (W*H*D)	inch(mm)	37.8*24.0*15.1 (960*610*384)	40.1*28.1*17.3 (1020*715*440)	40.1*28.1*17.3 (1020*715*440)	41.1*44.9*17.3 (1045*1140*440)	
Stuffing Quantity	With(Without) S/Parts	20/40ft	108/222 (108/222)	80/170(81/171)	80/170(81/171)	(51/111)

Notes: 1. Capacities are based on the following conditions:

Cooling: - Indoor Temperature 27°C(80.6°F) DB /19°C(66.2°F) WB
 - Outdoor Temperature 35°C(95°F) DB /24°C(75.2°F) WB
 - Interconnecting Piping Length 7.5m
 - Level Difference of Zero.

Heating: - Indoor Temperature 20°C(68°F) DB / 15°C(59°F) WB
 - Outdoor Temperature 7°C(44.6°F) DB / 6°C(42.8°F) WB
 - Interconnecting Piping Length 7.5 m
 - Level Difference of Zero.

2. Capacities are Net Capacities.

3. ★ : See the page "Combination Table"

4. Due to our policy of innovation some specifications may be changed without notification.

6. Combination Table

6.1 Cooling Only

6.1.1 A2UC146FA0

Cooling

Operation	Combination(k Btu)					Cooling							
						Capacity (Btu/h)					Input (W)	Current (A)	EER (Btu/h.W)
	A	B	C	D	Total	Unit-A	Unit-B	Unit-C	Unit-D	Total			
1 UNIT	7	-	-	-	7	9000	-	-	-	7000	1300	6.1	6.9
2 UNIT	7	7	-	-	14	7500	7500	-	-	15000	1400	6.7	10.7

6.1.2 A2UC186FA0

Cooling

Operation	Combination(k Btu)					Cooling							
						Capacity (Btu/h)					Input (W)	Current (A)	EER (Btu/h.W)
	A	B	C	D	Total	Unit-A	Unit-B	Unit-C	Unit-D	Total			
1 UNIT	7	-	-	-	7	7000	-	-	-	7000	780	3.5	9.0
	9	-	-	-	9	9500	-	-	-	9500	1100	5.0	8.6
	12	-	-	-	12	11000	-	-	-	11000	1100	5.0	10.0
2 UNIT	7	7	-	-	14	7000	7000	-	-	14000	1900	8.5	7.4
	7	9	-	-	16	7000	9000	-	-	16000	1900	8.5	8.4
	9	9	-	-	18	9000	9000	-	-	18000	1900	8.5	9.5
	7	12	-	-	19	7000	11000	-	-	18000	1900	8.5	9.5

6.1.3 A3UC216FA0

Cooling

Operation	Combination(k Btu)					Cooling							
						Capacity (Btu/h)					Input (W)	Current (A)	EER (Btu/h.W)
	A	B	C	D	Total	Unit-A	Unit-B	Unit-C	Unit-D	Total			
1 UNIT	7	-	-	-	7	8000	-	-	-	8000	880	4.0	9.1
	9	-	-	-	9	9500	-	-	-	9500	900	4.1	10.6
	12(Art)	-	-	-	12	11000	-	-	-	11000	1150	5.1	9.6
	12	-	-	-	12	12000	-	-	-	12000	1150	5.1	10.4
2 UNIT	7	7	-	-	14	8400	8400	-	-	16800	2100	9.4	8.0
	7	9	-	-	16	8000	10000	-	-	18000	2100	9.4	8.6
	9	9	-	-	18	9500	9500	-	-	19000	2100	9.4	9.0
	7	12(Art)	-	-	19	8000	11000	-	-	19000	2100	9.4	9.0
	7	12	-	-	19	8000	12000	-	-	20000	2100	9.4	9.5
	9	12	-	-	21	9000	12000	-	-	21000	2100	9.4	10.0
3 UNIT	7	7	7	-	21	7000	7000	7000	-	21000	2100	9.4	10.0
	7	7	9	-	23	6400	6400	8200	-	21000	2100	9.4	10.0



6. Combination Table

6.1.4 A4UC306FA0

Cooling

Operation	Combination(k Btu)					Cooling							
						Capacity (Btu/h)					Input (W)	Current (A)	EER (Btu/h.W)
	A	B	C	D	Total	Unit-A	Unit-B	Unit-C	Unit-D	Total			
1 UNIT	7				7	9000				9000	1200	5.2	7.5
	9				9	10000				10000	1200	5.2	8.3
	12				12	12000				12000	1200	5.2	10.0
	18				18	18000				18000	1950	9.1	9.2
	24				24	24000				24000	3250	15.0	7.4
2 UNIT	7	7			14	8000	8000			16000	1950	9.1	8.2
	7	9			16	7500	9500			17000	1950	9.1	8.7
	7	12			19	7000	12000			19000	1950	9.1	9.7
	7	18			25	9000	19000			28000	3250	15.0	8.6
	7	24			31	7000	23000			30000	3250	15.0	9.2
	9	9			18	9000	9000			18000	1950	9.1	9.2
	9	12			21	11000	14000			25000	3250	15.0	7.7
	9	18			27	10000	18000			28000	3250	15.0	8.6
	9	24			33	8000	22000			30000	3250	15.0	9.2
	12	12			24	13000	13000			26000	3250	15.0	8.0
12	18			30	12000	18000			30000	3250	15.0	9.2	
3 UNIT	7	7	7		21	9000	9000	9000		27000	3250	15.0	8.3
	7	7	9		23	9000	9000	11000		29000	3250	15.0	8.9
	7	7	12		26	8000	8000	12000		28000	3250	15.0	8.6
	7	7	18		32	6500	6500	17000		30000	3250	15.0	9.2
	7	9	9		25	9000	10000	10000		29000	3250	15.0	8.9
	7	9	12		28	7500	9500	12000		29000	3250	15.0	8.9
	7	12	12		31	7000	11500	11500		30000	3250	15.0	9.2
	9	9	9		27	10000	10000	10000		30000	3250	15.0	9.2
	9	9	12		30	9000	9000	12000		30000	3250	15.0	9.2
9	12	12		33	8000	11000	11000		30000	3250	15.0	9.2	
4 UNIT	7	7	7	7	28	7500	7500	7500	7500	30000	3250	15.0	9.2
	7	7	7	9	30	7000	7000	7000	9000	30000	3250	15.0	9.2
	7	7	7	12	33	6500	6500	6500	10500	30000	3250	15.0	9.2
	7	7	9	9	32	6500	6500	8500	8500	30000	3250	15.0	9.2

6. Combination Table

6.2 Heat Pump

6.2.1 A2UH146FA0

Cooling

Operation	Combination(k Btu)					Cooling								
						Capacity (Btu/h)					Input (W)	Current (A)	EER (Btu/h.W)	
	A	B	C	D	Total	Unit-A	Unit-B	Unit-C	Unit-D	Total				
1 UNIT	7	-	-	-	7	9400	-	-	-	-	9400	1350	6.1	7.0
2 UNIT	7	7	-	-	14	7200	7200	-	-	-	14400	1450	6.6	9.9

Heating

Operation	Combination(k Btu)					Heating								
						Capacity (Btu/h)					Input (W)	Current (A)	EER (Btu/h.W)	
	A	B	C	D	Total	Unit-A	Unit-B	Unit-C	Unit-D	Total				
1 UNIT	7	-	-	-	7	10000	-	-	-	-	10000	1500	7.0	6.7
2 UNIT	7	7	-	-	14	7300	7300	-	-	-	14600	1300	6.0	11.2

6.2.2 A2UH186FA0

Cooling

Operation	Combination(k Btu)					Cooling								
						Capacity (Btu/h)					Input (W)	Current (A)	EER (Btu/h.W)	
	A	B	C	D	Total	Unit-A	Unit-B	Unit-C	Unit-D	Total				
1 UNIT	7	-	-	-	7	7000	-	-	-	-	7000	780	3.5	9.0
	9	-	-	-	9	9500	-	-	-	-	9500	1100	5.0	8.6
	12	-	-	-	12	11000	-	-	-	-	11000	1100	5.0	10.0
2 UNIT	7	7	-	-	14	7000	7000	-	-	-	14000	1900	8.5	7.4
	7	9	-	-	16	7000	9000	-	-	-	16000	1900	8.5	8.4
	9	9	-	-	18	9000	9000	-	-	-	18000	1900	8.5	9.5
	7	12	-	-	19	7000	11000	-	-	-	18000	1900	8.5	9.5

Heating

Operation	Combination(k Btu)					Heating								
						Capacity (Btu/h)					Input (W)	Current (A)	EER (Btu/h.W)	
	A	B	C	D	Total	Unit-A	Unit-B	Unit-C	Unit-D	Total				
1 UNIT	7	-	-	-	7	9000	-	-	-	-	9000	1300	6.0	6.9
	9	-	-	-	9	10500	-	-	-	-	10500	1250	5.6	8.4
	12	-	-	-	12	12100	-	-	-	-	12100	1200	5.5	10.1
2 UNIT	7	7	-	-	14	7700	7700	-	-	-	15400	1900	8.5	8.1
	7	9	-	-	16	7700	9900	-	-	-	17600	1900	8.5	9.3
	9	9	-	-	18	9900	9900	-	-	-	19800	1900	8.5	10.4
	7	12	-	-	19	7700	12100	-	-	-	19800	1900	8.5	10.4



6. Combination Table

6.2.3 A3UH216FA0

Cooling

Operation	Combination(k Btu)					Cooling							
						Capacity (Btu/h)					Input (W)	Current (A)	EER (Btu/h.W)
	A	B	C	D	Total	Unit-A	Unit-B	Unit-C	Unit-D	Total			
1 UNIT	7	-	-	-	7	8000	-	-	-	8000	880	4.0	9.1
	9	-	-	-	9	9500	-	-	-	9500	900	4.1	10.6
	12(Art)	-	-	-	12	11000	-	-	-	11000	1150	5.1	9.6
	12	-	-	-	12	12000	-	-	-	12000	1150	5.1	10.4
2 UNIT	7	7	-	-	14	8400	8400	-	-	16800	2100	9.4	8.0
	7	9	-	-	16	8000	10000	-	-	18000	2100	9.4	8.6
	9	9	-	-	18	9500	9500	-	-	19000	2100	9.4	9.0
	7	12(Art)	-	-	19	8000	11000	-	-	19000	2100	9.4	9.0
	7	12	-	-	19	8000	12000	-	-	20000	2100	9.4	9.5
	9	12	-	-	21	9000	12000	-	-	21000	2100	9.4	10.0
3 UNIT	7	7	7	-	21	7000	7000	7000	-	21000	2100	9.4	10.0
	7	7	9	-	23	6400	6400	8200	-	21000	2100	9.4	10.0

Heating

Operation	Combination(k Btu)					Heating							
						Capacity (Btu/h)					Input (W)	Current (A)	EER (Btu/h.W)
	A	B	C	D	Total	Unit-A	Unit-B	Unit-C	Unit-D	Total			
1 UNIT	7	-	-	-	7	9000	-	-	-	9000	1350	6.0	6.7
	9	-	-	-	9	10450	-	-	-	10450	1350	6.2	7.7
	12(Art)	-	-	-	12	12100	-	-	-	12100	1400	6.2	8.6
	12	-	-	-	12	13200	-	-	-	13200	1400	6.2	9.4
2 UNIT	7	7	-	-	14	9200	9200	-	-	18400	2200	9.8	8.4
	7	9	-	-	16	8800	11000	-	-	19800	2200	9.8	9.0
	9	9	-	-	18	10000	10000	-	-	20000	2200	9.8	9.1
	7	12(Art)	-	-	19	8800	12100	-	-	20900	2200	9.8	9.5
	7	12	-	-	19	8400	12600	-	-	21000	2200	9.8	9.5
	9	12	-	-	21	9000	12000	-	-	21000	1900	8.5	11.1
3 UNIT	7	7	7	-	21	7000	7000	7000	-	21000	1900	8.5	11.1
	7	7	9	-	23	6400	6400	8200	-	21000	1900	8.5	11.1

6. Combination Table

6.2.4 A4UH306FA0

Cooling

Operation	Combination(k Btu)					Cooling							
						Capacity (Btu/h)					Input (W)	Current (A)	EER (Btu/h.W)
	A	B	C	D	Total	Unit-A	Unit-B	Unit-C	Unit-D	Total			
1 UNIT	7	-	-	-	7	9000	-	-	-	9000	1200	5.2	7.5
	9	-	-	-	9	10000	-	-	-	10000	1200	5.2	8.3
	12	-	-	-	12	12000	-	-	-	12000	1200	5.2	10.0
	18	-	-	-	18	18000	-	-	-	18000	1950	9.1	9.2
	24	-	-	-	24	24000	-	-	-	24000	3250	15.0	7.4
2 UNIT	7	7	-	-	14	8000	8000	-	-	16000	1950	9.1	8.2
	7	9	-	-	16	7500	9500	-	-	17000	1950	9.1	8.7
	7	12	-	-	19	7000	12000	-	-	19000	1950	9.1	9.7
	7	18	-	-	25	9000	19000	-	-	28000	3250	15.0	8.6
	7	24	-	-	31	7000	23000	-	-	30000	3250	15.0	9.2
	9	9	-	-	18	9000	9000	-	-	18000	1950	9.1	9.2
	9	12	-	-	21	11000	14000	-	-	25000	3250	15.0	7.7
	9	18	-	-	27	10000	18000	-	-	28000	3250	15.0	8.6
	9	24	-	-	33	8000	22000	-	-	30000	3250	15.0	9.2
	12	12	-	-	24	13000	13000	-	-	26000	3250	15.0	8.0
12	18	-	-	30	12000	18000	-	-	30000	3250	15.0	9.2	
3 UNIT	7	7	7	-	21	9000	9000	9000	-	27000	3250	15.0	8.3
	7	7	9	-	23	9000	9000	11000	-	29000	3250	15.0	8.9
	7	7	12	-	26	8000	8000	12000	-	28000	3250	15.0	8.6
	7	7	18	-	32	6500	6500	17000	-	30000	3250	15.0	9.2
	7	9	9	-	25	9000	10000	10000	-	29000	3250	15.0	8.9
	7	9	12	-	28	7500	9500	12000	-	29000	3250	15.0	8.9
	7	12	12	-	31	7000	11500	11500	-	30000	3250	15.0	9.2
	9	9	9	-	27	10000	10000	10000	-	30000	3250	15.0	9.2
	9	9	12	-	30	9000	9000	12000	-	30000	3250	15.0	9.2
9	12	12	-	33	8000	11000	11000	-	30000	3250	15.0	9.2	
4 UNIT	7	7	7	7	28	7500	7500	7500	7500	30000	3250	15.0	9.2
	7	7	7	9	30	7000	7000	7000	9000	30000	3250	15.0	9.2
	7	7	7	12	33	6500	6500	6500	10500	30000	3250	15.0	9.2
	7	7	9	9	32	6500	6500	8500	8500	30000	3250	15.0	9.2



6. Combination Table

Heating

Operation	Combination(k Btu)					Heating							
						Capacity (Btu/h)					Input (W)	Current (A)	EER (Btu/h.W)
	A	B	C	D	Total	Unit-A	Unit-B	Unit-C	Unit-D	Total			
1 UNIT	7	-	-	-	7	10000	-	-	-	10000	1310	6.0	7.6
	9	-	-	-	9	11000	-	-	-	11000	1310	6.0	8.4
	12	-	-	-	12	12000	-	-	-	12000	1310	6.0	9.2
	18	-	-	-	18	18000	-	-	-	18000	2050	9.7	8.8
	24	-	-	-	24	26400	-	-	-	26400	3360	15.5	7.9
2 UNIT	7	7	-	-	14	8800	8800	-	-	17600	2050	9.7	8.6
	7	9	-	-	16	8200	10400	-	-	18600	2050	9.7	9.1
	7	12	-	-	19	7000	12000	-	-	19000	2050	9.7	9.3
	7	18	-	-	25	9900	20900	-	-	30800	3360	15.5	9.2
	7	24	-	-	31	7700	25000	-	-	32700	3360	15.5	9.7
	9	9	-	-	18	9900	9900	-	-	19800	2050	9.7	9.7
	9	12	-	-	21	12100	15400	-	-	27500	3360	15.5	8.2
	9	18	-	-	27	11000	19800	-	-	30800	3360	15.5	9.2
	9	24	-	-	33	8800	24200	-	-	33000	3360	15.5	9.8
	12	12	-	-	24	14300	14300	-	-	28600	3360	15.5	8.5
	12	18	-	-	30	13200	19800	-	-	33000	3360	15.5	9.8
3 UNIT	7	7	7	-	21	9900	9900	9900	-	29700	3360	15.5	8.8
	7	7	9	-	23	9900	9900	12100	-	31900	3360	15.5	9.5
	7	7	12	-	26	8800	8800	13200	-	30800	3360	15.5	9.2
	7	7	18	-	32	7100	7100	18700	-	32900	3360	15.5	9.8
	7	9	9	-	25	9900	11000	11000	-	31900	3360	15.5	9.5
	7	9	12	-	28	8200	10400	13200	-	31800	3360	15.5	9.5
	7	12	12	-	31	7700	12600	12600	-	32900	3360	15.5	9.8
	9	9	9	-	27	11000	11000	11000	-	33000	3360	15.5	9.8
	9	9	12	-	30	9900	9900	13200	-	33000	3360	15.5	9.8
4 UNIT	9	12	12	-	33	8800	12100	12100	-	33000	3360	15.5	9.8
	7	7	7	7	28	8200	8200	8200	8200	32800	3360	15.5	9.8
	7	7	7	9	30	7700	7700	7700	9900	33000	3360	15.5	9.8
	7	7	7	12	33	7100	7100	7100	12100	33400	3360	15.5	9.9
	7	7	9	9	32	7100	7100	9300	9300	32800	3360	15.5	9.8

7. Dimensional Drawings

7.1 Indoor Units

AMNC-LQ/LR/LT, AMNH-LQ/LR/LT

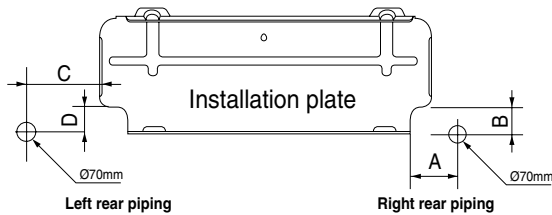
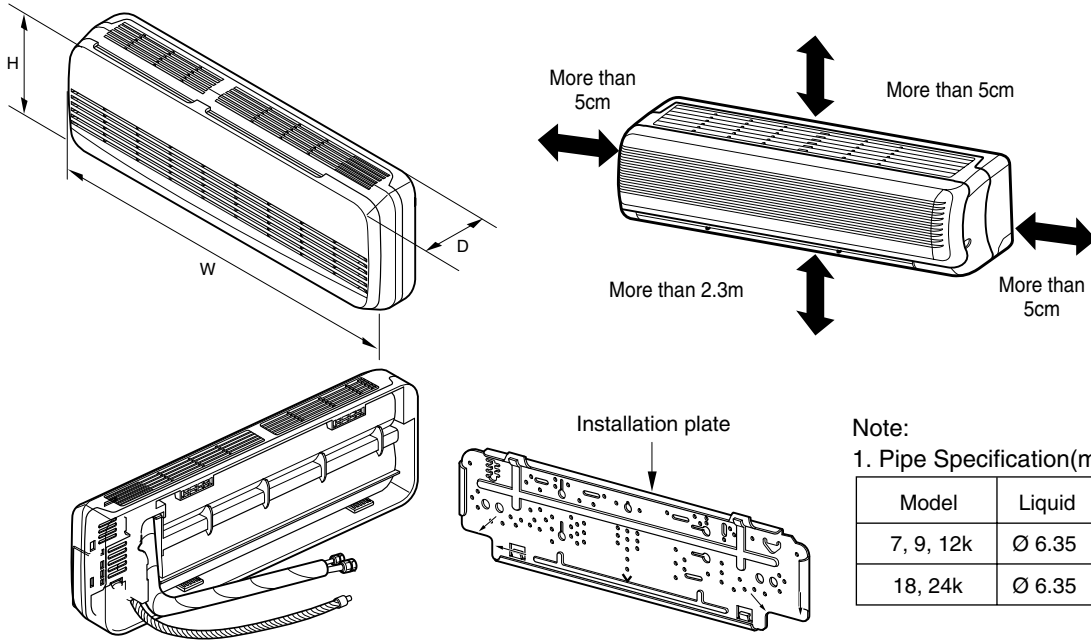

CHASSIS (Grade)	Distance(mm)			
	A	B	C	D
SQ(7/9k)	75	12	80	12
SR(12k)	0	40	20	40
ST(18/24k)	105	0	210	0

(unit : mm)

Model	W	H	D
AMNC/H076LQL0	824	260	155
AMNC/H096LQL0			
AMNC/H126LRL0	900	285	156
AMNC/H186LTL0	1090	314	172
AMNC/H246LTL0			



7. Dimensional Drawings

AMNC-AP, AMNH-AP

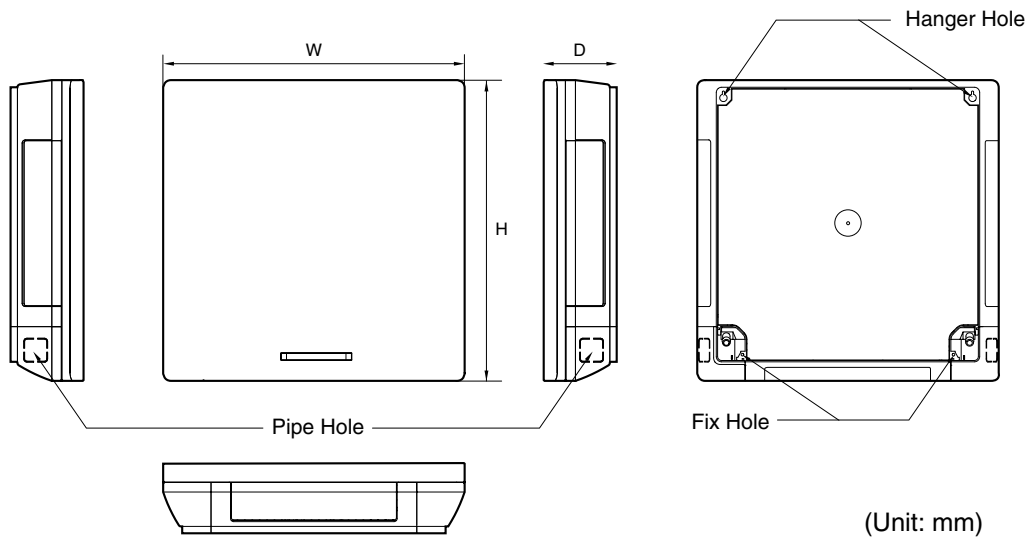

Note:

1. Pipe Specification(mm)

Model	Liquid	Gas
9, 12k	Ø 6.35	Ø 9.52

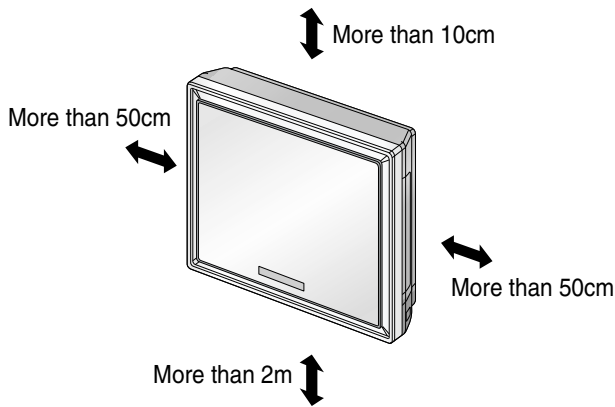

(unit : mm)

Model	W	H	D
AMNC/H096AP*1	570	568	129
AMNC/H126AP*1			

7. Dimensional Drawings

7.2 Outdoor Units

A2UC146FA0, A2UH146FA0

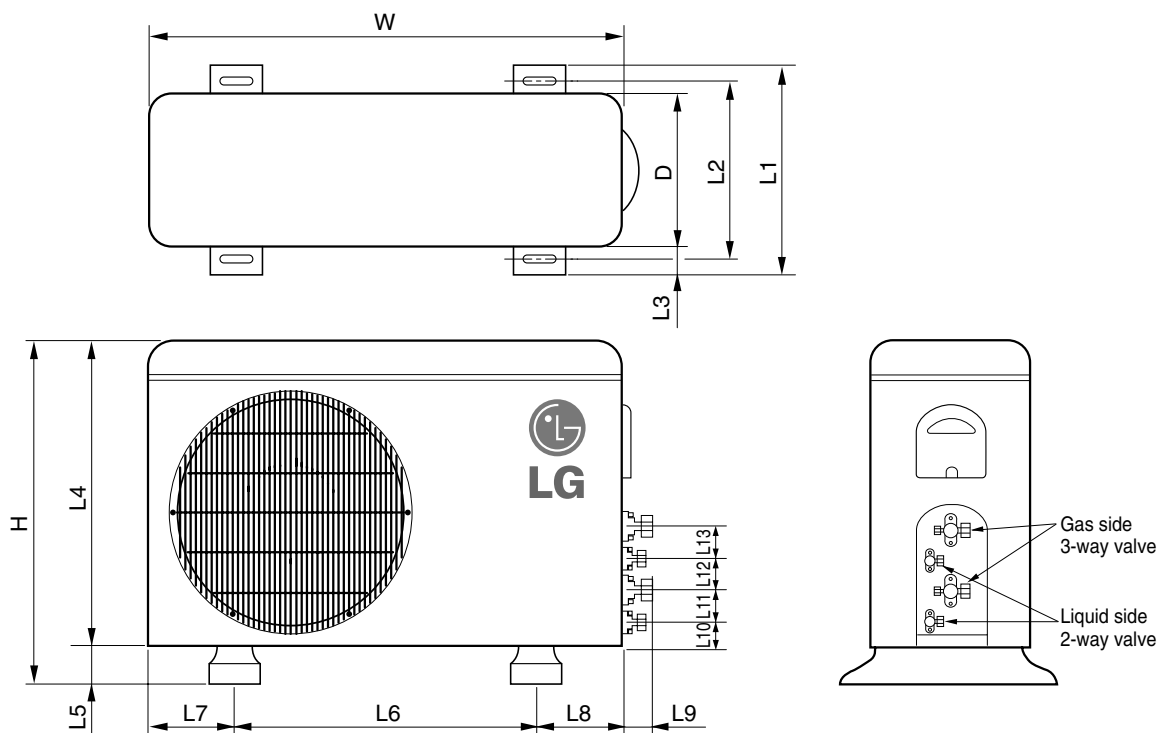

Model		A2UC146FA0, A2UH146FA0
Dimensions		
W	mm	801
H	mm	555
D	mm	262
L1	mm	339
L2	mm	300
L3	mm	37
L4	mm	543.6
L5	mm	11.4
L6	mm	591
L7	mm	105
L8	mm	105
L9	mm	72.5
L10	mm	74.5
L11	mm	79



7. Dimensional Drawings

A2UC186FA0, A2UH186FA0

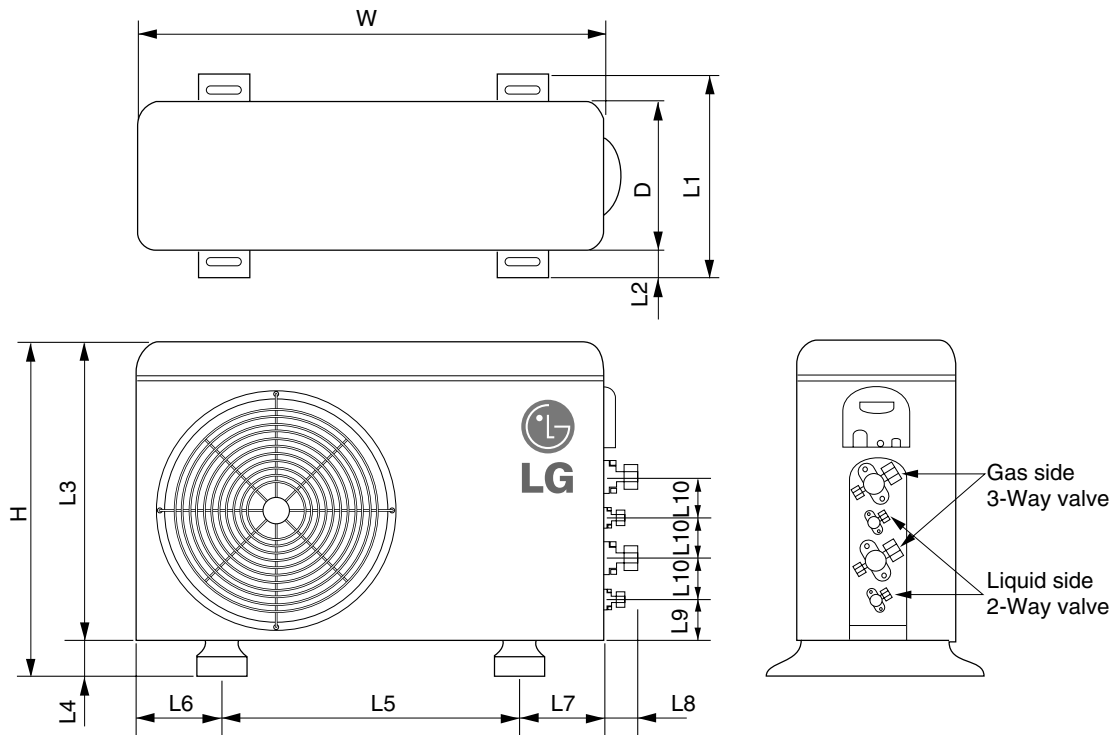

Model		A2UC186FA0, A2UH186FA0
Dimensions		
W	mm	870
H	mm	655
D	mm	320
L1	mm	370
L2	mm	25
L3	mm	630
L4	mm	25
L5	mm	546
L6	mm	160
L7	mm	160
L8	mm	64
L9	mm	76.5
L10	mm	50

7. Dimensional Drawings

A3UC216FA0, A3UH216FA0

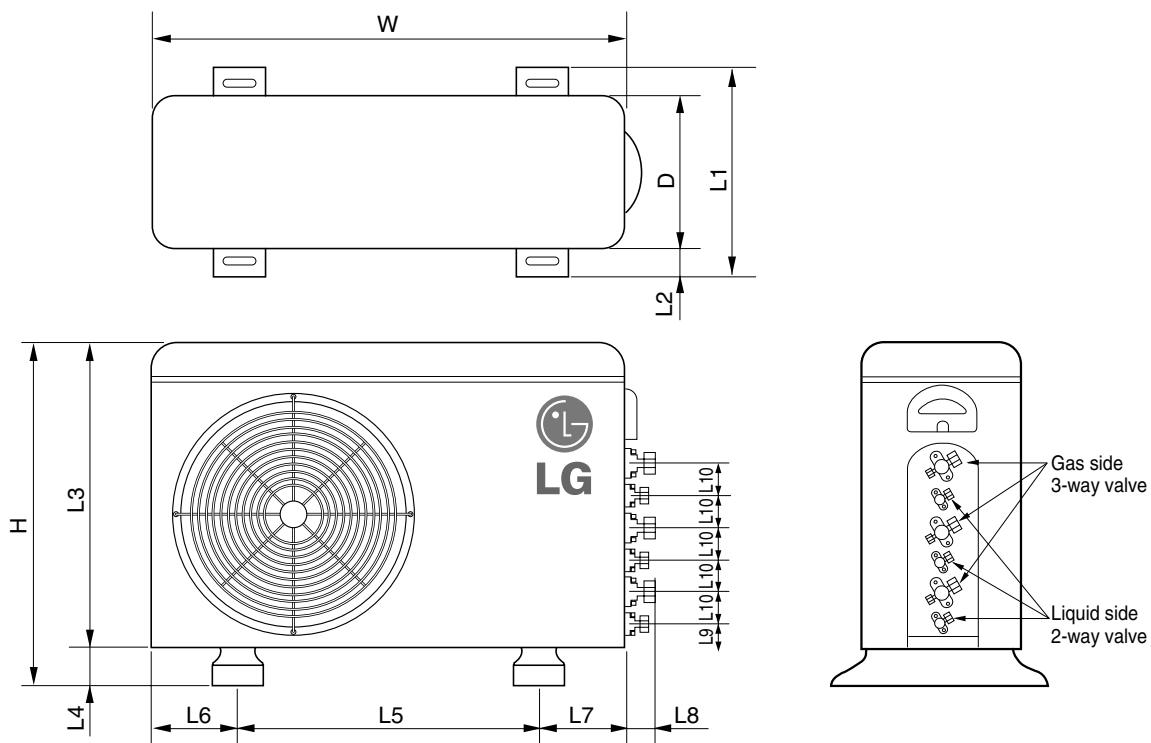

Model		A3UC216FA0, A3UH216FA0
Dimensions		
W	mm	870
H	mm	655
D	mm	320
L1	mm	370
L2	mm	25
L3	mm	630
L4	mm	25
L5	mm	546
L6	mm	160
L7	mm	160
L8	mm	64
L9	mm	76.5
L10	mm	50



7. Dimensional Drawings

A4UC306FA0, A4UH306FA0

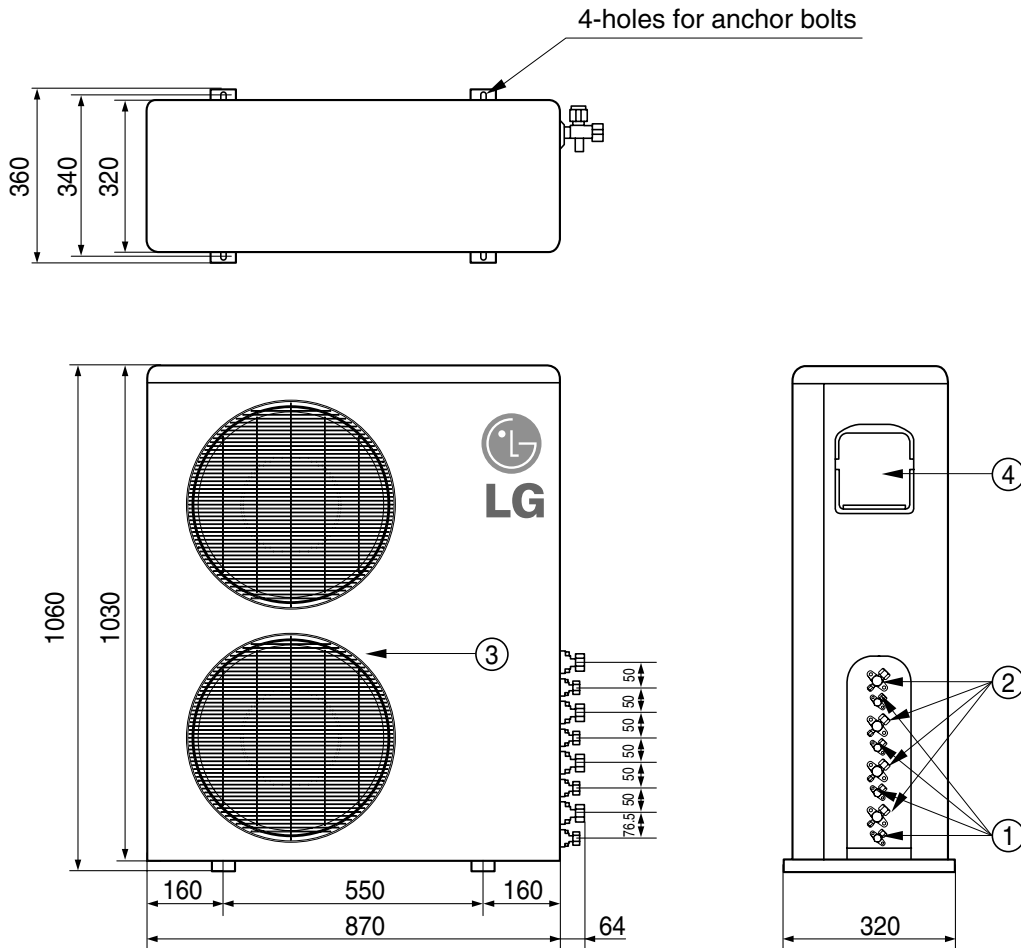

Number	Name	Description
1	Liquid side service valve(mm)	Ø6.35
2	Gas side service valve(mm)	Ø9.52
3	Air discharge grill	
4	Control Cover	

8. Wiring Diagrams

8.1 Indoor Unit

Wall Mounted

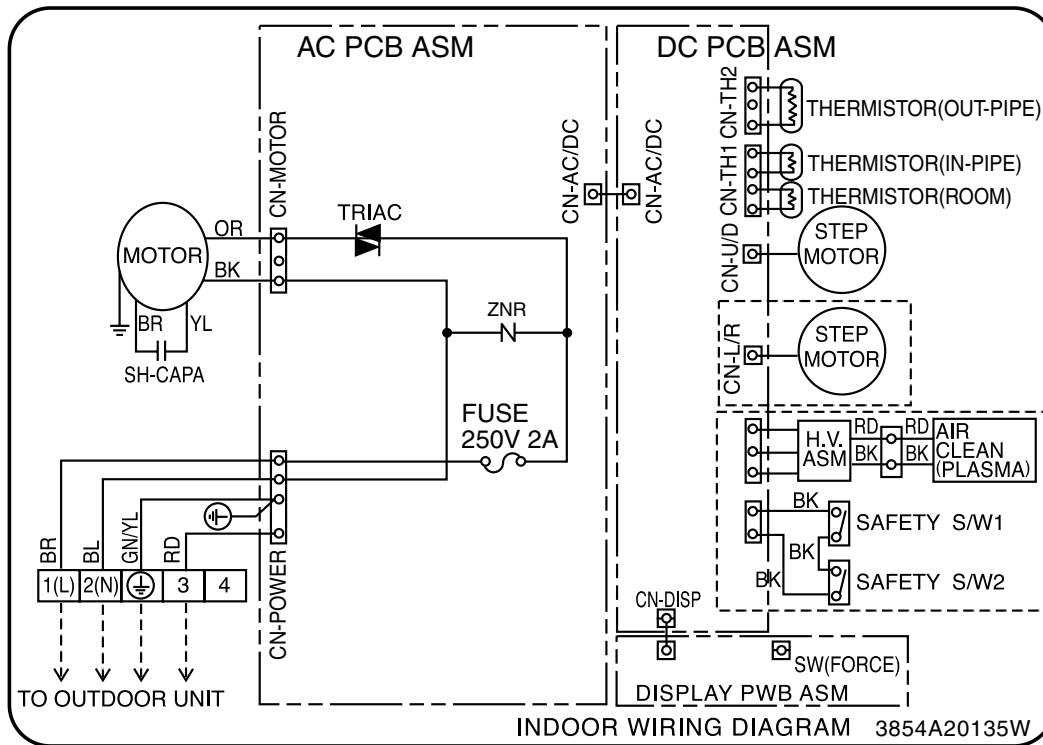

CONNECTOR NUMBER	Location
CN-POWER	AC POWER SUPPLY
CN-MOTOR	AC FAN MOTOR OUTPUT
CN-ACDC	AC/DC CONNECTION
CN-COMM	COMMUNICATION
CN-DISP	DISPLAY
CN-DISP2	DISPLAY
CN-UD	STEP MOTOR
CN-LR	STEP MOTOR
CN-TH1	ROOM/PIPE SENSOR
CN-TH2	DISCHARGE PIPE SENSOR



8. Wiring Diagrams

ART COOL Type

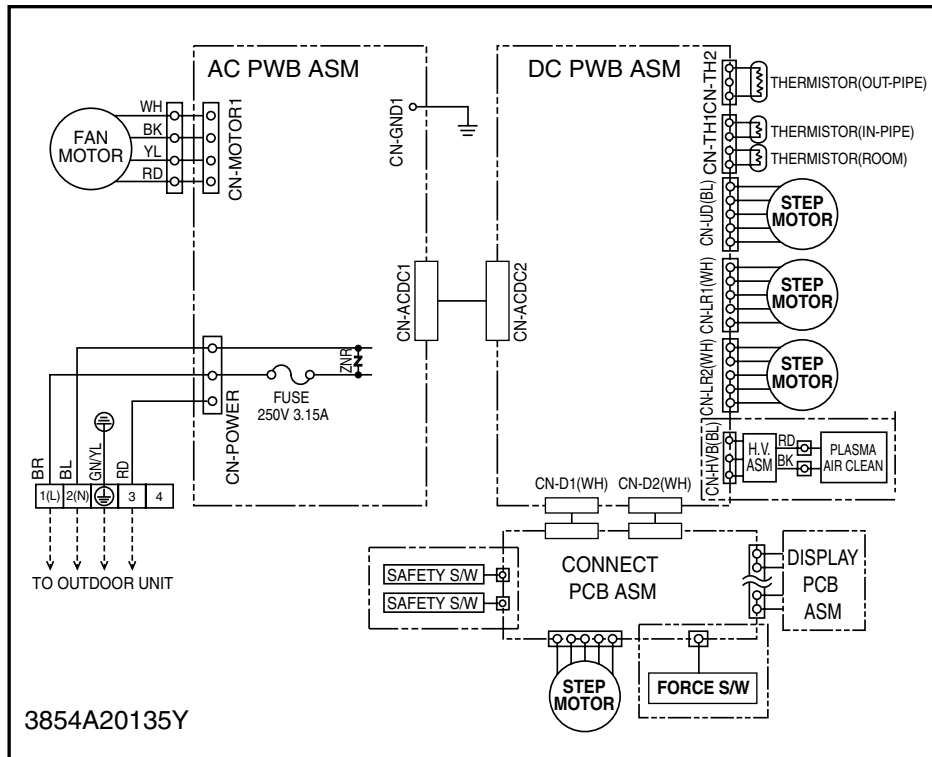

CONNECTOR NUMBER	LOCATION
CN-POWER	AC POWER SUPPLY
CN-MOTOR	BLDC FAN MOTOR OUTPUT
CN-D1	DISPLAY
CN-D2	DISPLAY
CN-LR1	STEP MOTOR
CN-LR2	STEP MOTOR
CN-UD	STEP MOTOR
CN-TH1	ROOM/PIPE SENSOR
CN-TH2	DISCHARGE PIPE SENSOR

8. Wiring Diagrams

8.2 Outdoor Unit

A2UC146FA0

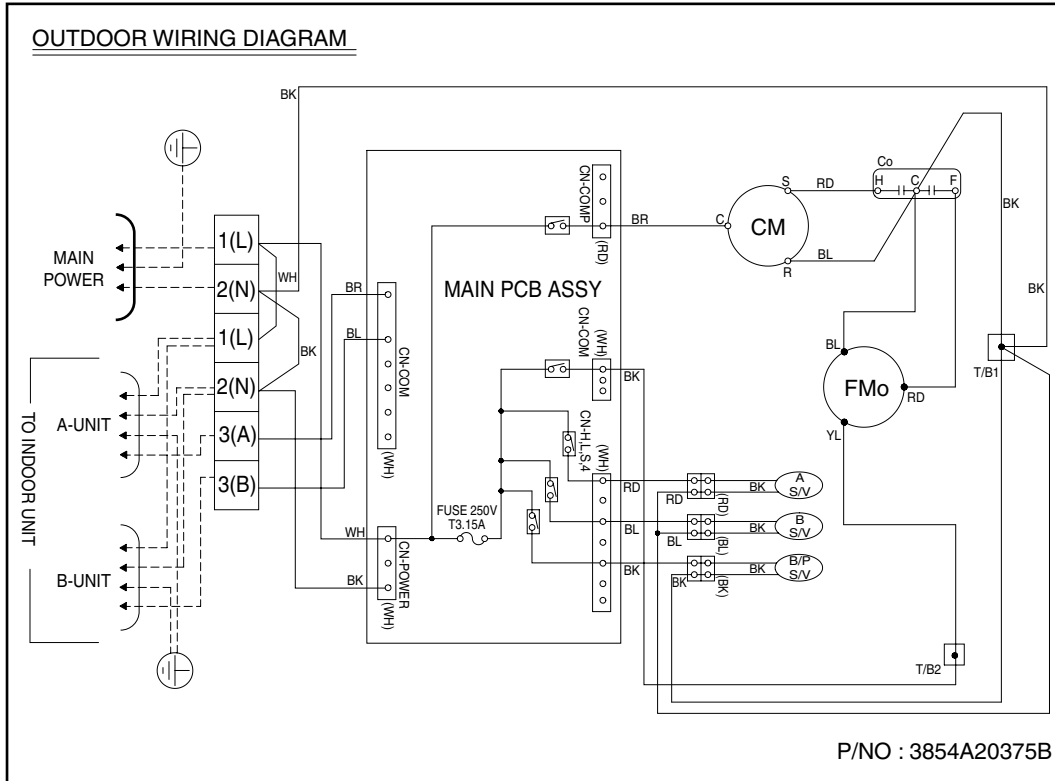

Notes:

BL	BLUE	BK	BLACK	BR	BROWN
RD	RED	OR	ORANGE	WH	WHITE
YL	YELLOW	GN/YL	GREEN/YELLOW	CN	CONNECTOR



8. Wiring Diagrams

A2UC186FA0

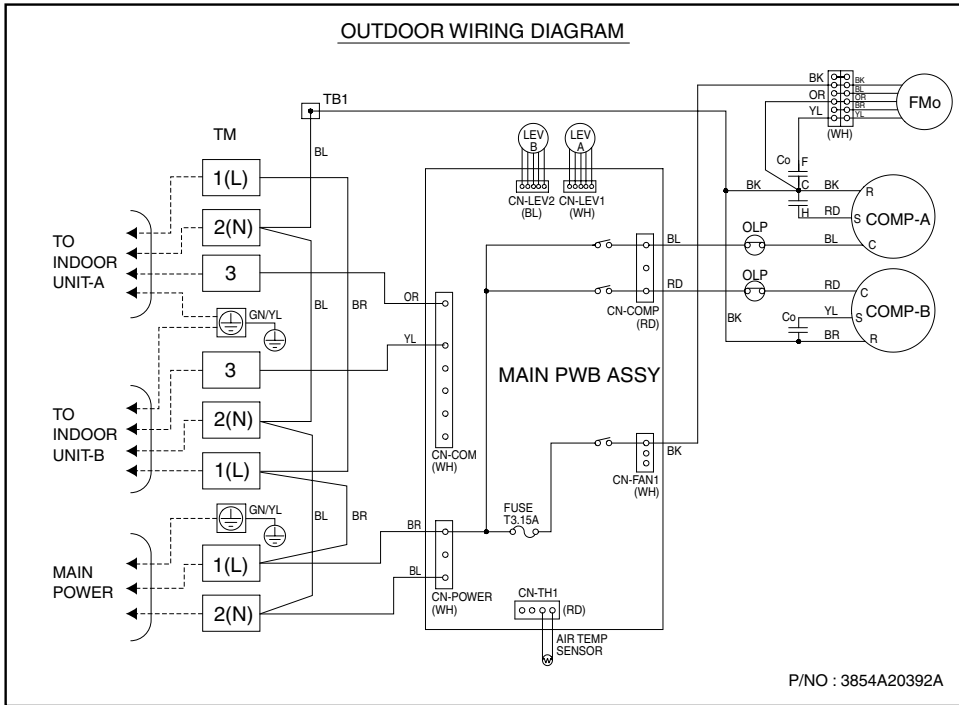

Notes:

BL	BLUE	BK	BLACK	BR	BROWN
RD	RED	OR	ORANGE	WH	WHITE
YL	YELLOW	GN/YL	GREEN/YELLOW	CN	CONNECTOR

8. Wiring Diagrams

A3UC216FA0

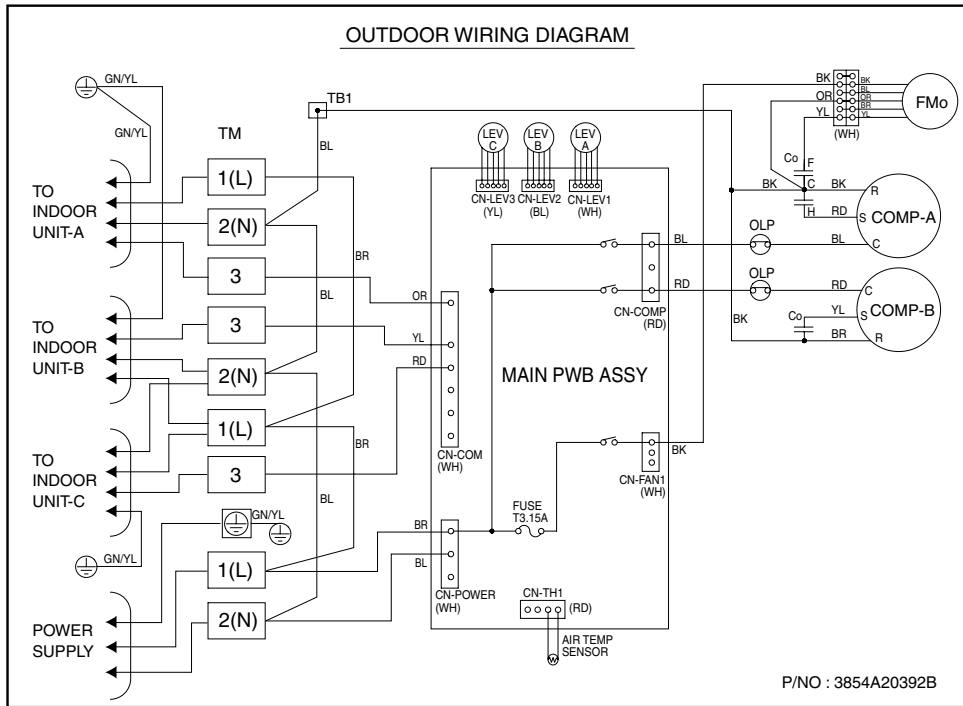

Notes:

BL	BLUE	BK	BLACK	BR	BROWN
RD	RED	OR	ORANGE	WH	WHITE
YL	YELLOW	GN/YL	GREEN/YELLOW	CN	CONNECTOR



8. Wiring Diagrams

A4UC306FA0

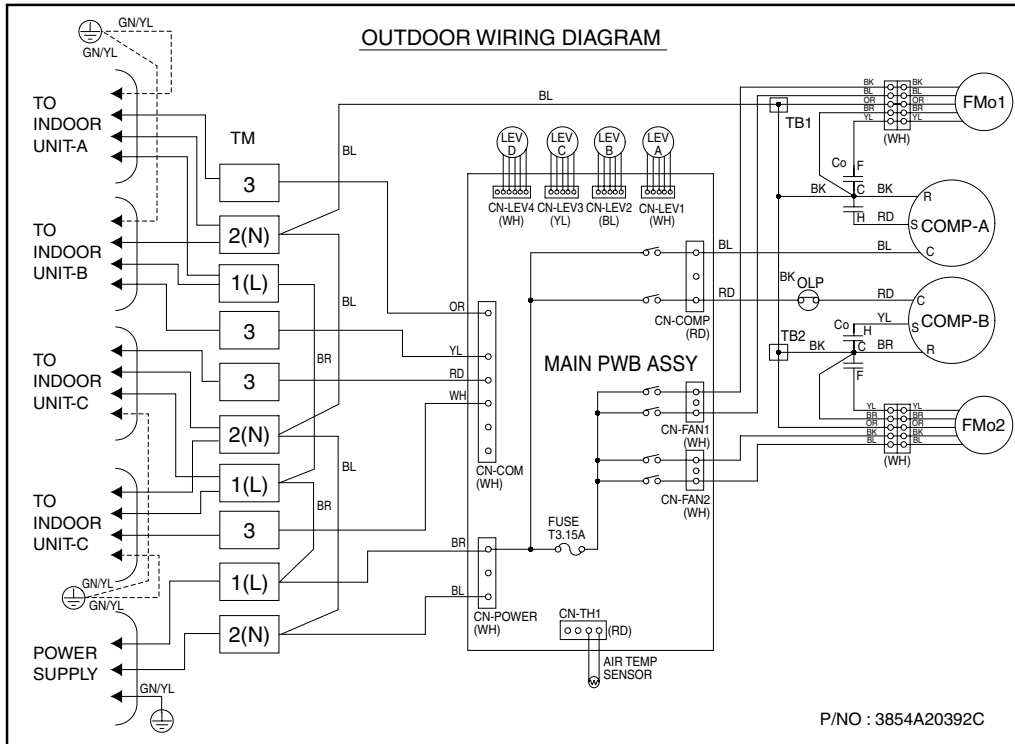

Notes:

BL	BLUE	BK	BLACK	BR	BROWN
RD	RED	OR	ORANGE	WH	WHITE
YL	YELLOW	GN/YL	GREEN/YELLOW	CN	CONNECTOR

8. Wiring Diagrams

A2UH146FA0

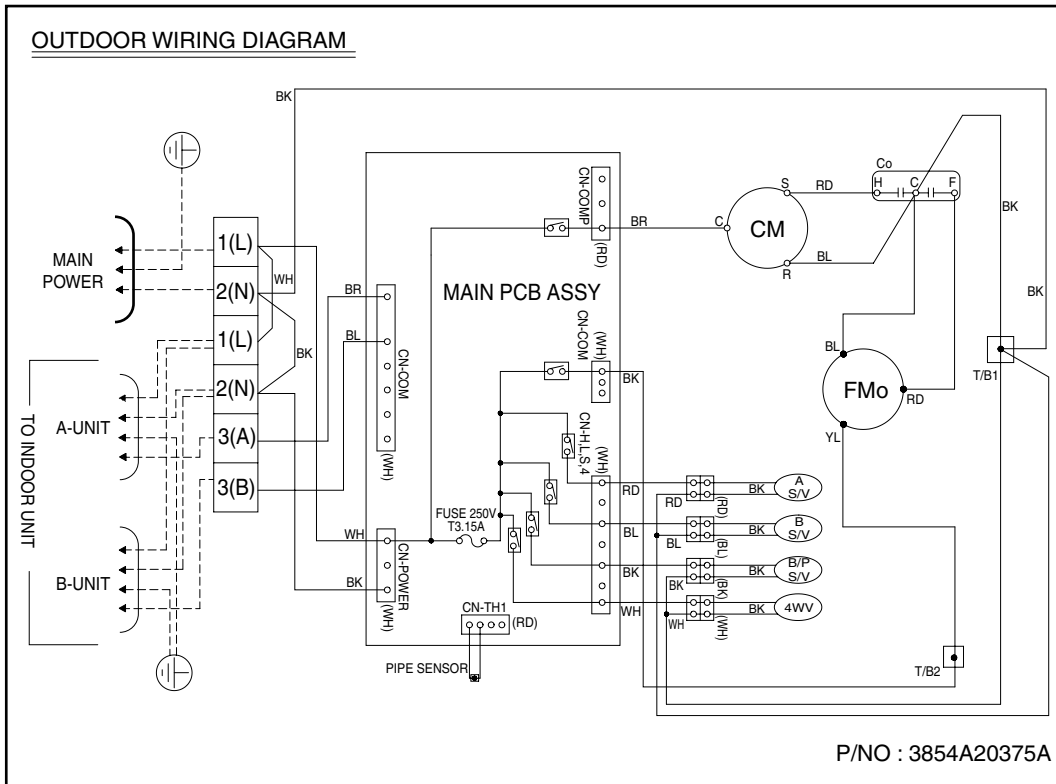

Notes:

BL	BLUE	BK	BLACK	BR	BROWN
RD	RED	OR	ORANGE	WH	WHITE
YL	YELLOW	GN/YL	GREEN/YELLOW	CN	CONNECTOR



8. Wiring Diagrams

A2UH186FA0

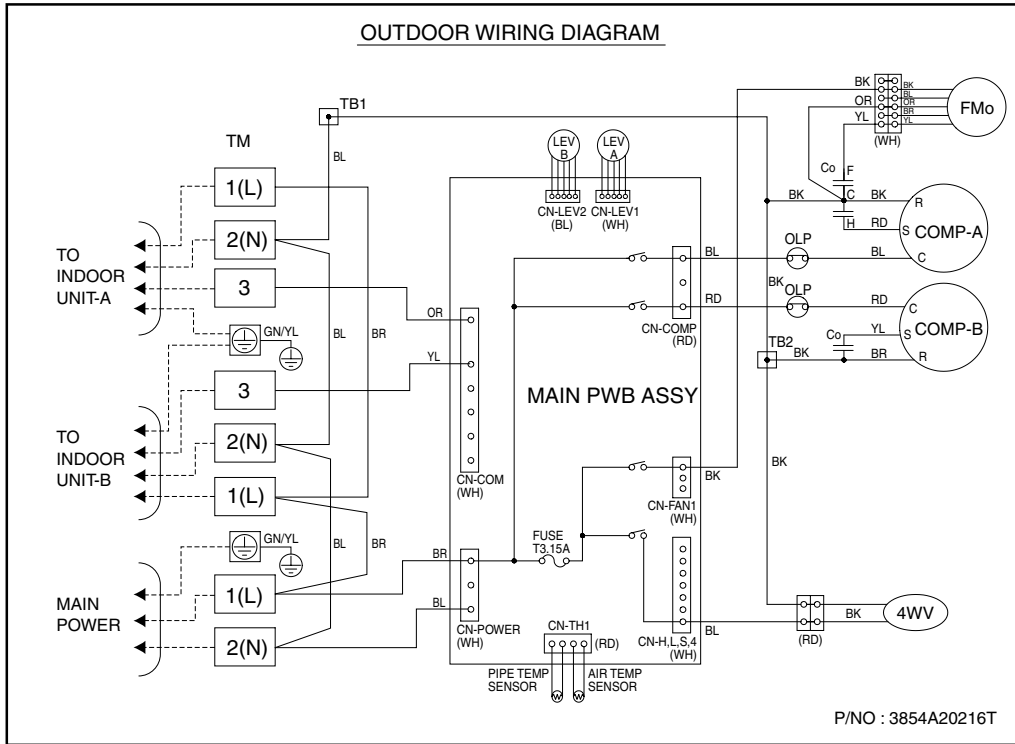

Notes:

BL	BLUE	BK	BLACK	BR	BROWN
RD	RED	OR	ORANGE	WH	WHITE
YL	YELLOW	GN/YL	GREEN/YELLOW	CN	CONNECTOR

8. Wiring Diagrams

A3UH216FA0

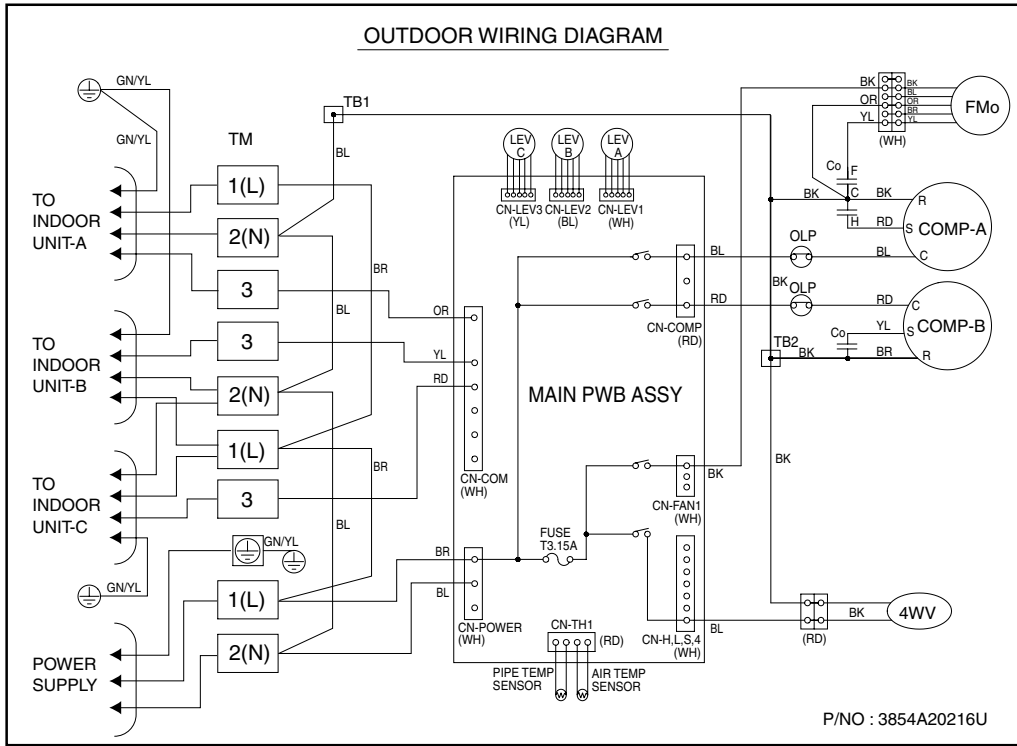

Notes:

BL	BLUE	BK	BLACK	BR	BROWN
RD	RED	OR	ORANGE	WH	WHITE
YL	YELLOW	GN/YL	GREEN/YELLOW	CN	CONNECTOR



8. Wiring Diagrams

A4UH306FA0

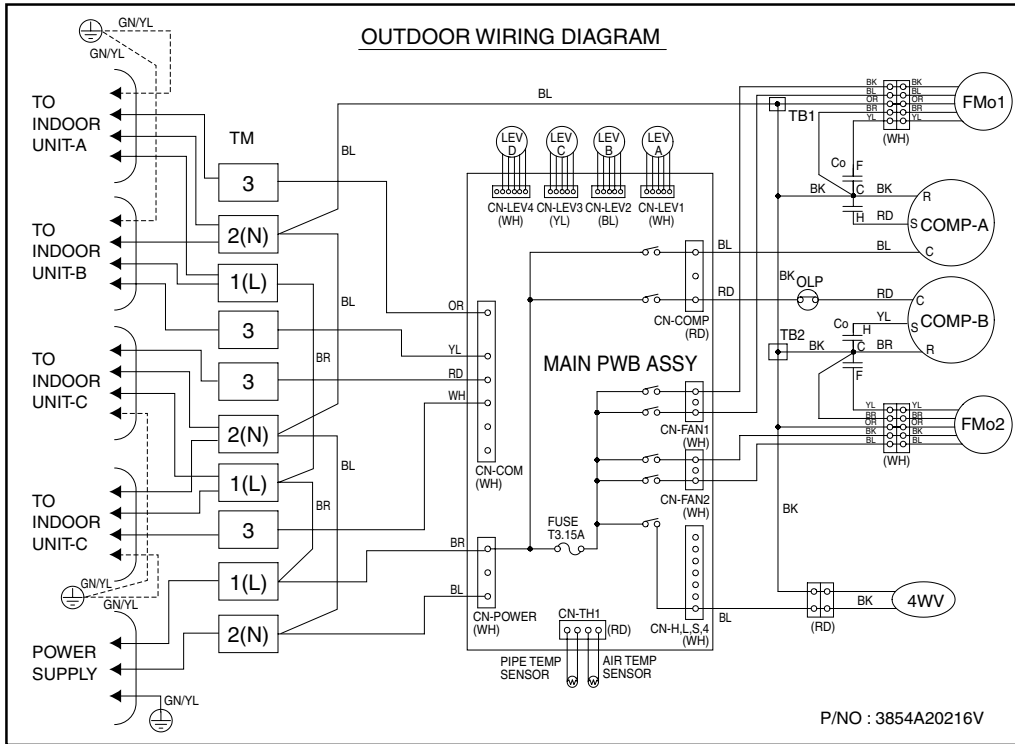

Notes:

BL	BLUE	BK	BLACK	BR	BROWN
RD	RED	OR	ORANGE	WH	WHITE
YL	YELLOW	GN/YL	GREEN/YELLOW	CN	CONNECTOR

9. Piping Diagrams

9.1 Indoor Unit

9.1.1 Cooling Only

Wall Mounted

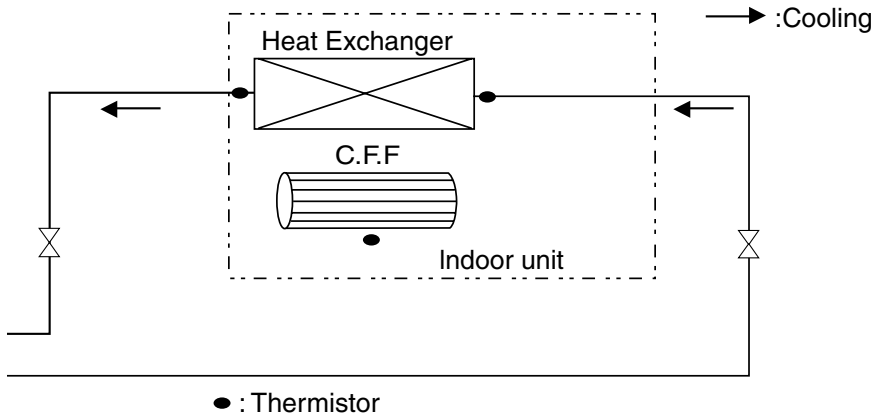

Refrigerant pipe connection port diameter
[unit:mm(inch)]

Model	Gas	Liquid
AMNC076LQL0	Ø9.52(3/8)	Ø6.35(1/4)
AMNC096LQL0		
AMNC126LRL0		
AMNC186LTLO	Ø12.7(1/2)	
AMNC246LTLO		

ART COOL

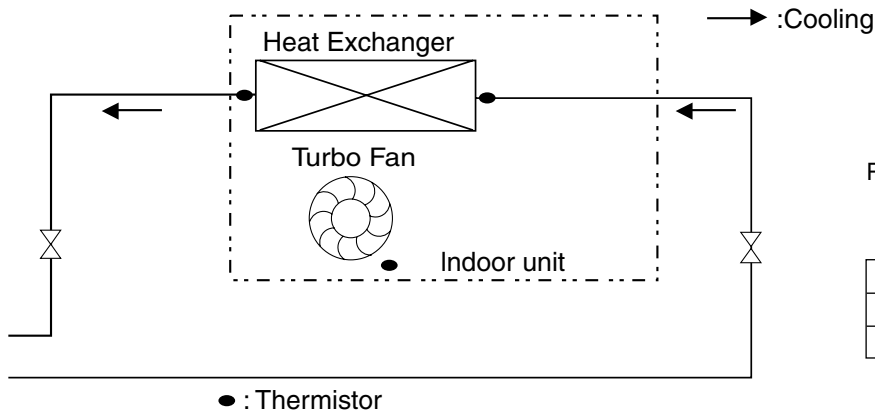

Refrigerant pipe connection port diameter
[unit:mm(inch)]

Model	Gas	Liquid
AMNC096AP*1	Ø9.52(3/8)	Ø6.35(1/4)
AMNC126AP*1		



9. Piping Diagrams

9.1.2 Heat Pump

Wall Mounted

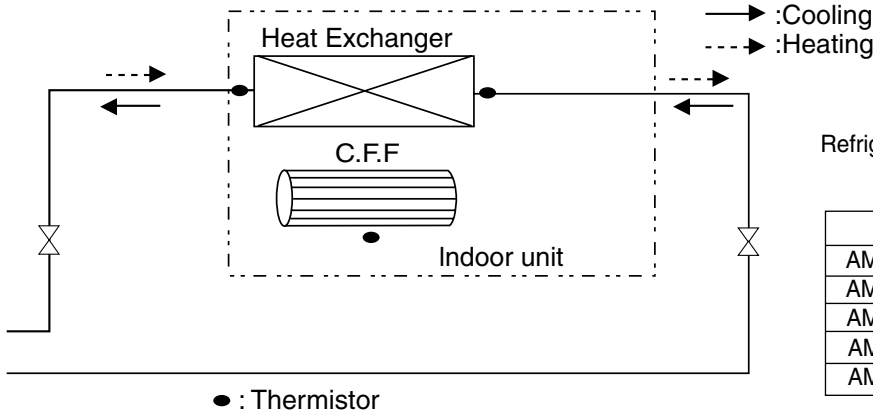

Refrigerant pipe connection port diameter
[unit:mm(inch)]

Model	Gas	Liquid
AMNH076LQL0	Ø9.52(3/8)	Ø6.35(1/4)
AMNH096LQL0		
AMNH126LRL0		
AMNH186LTLO	Ø12.7(1/2)	
AMNH246LTLO		

ART COOL

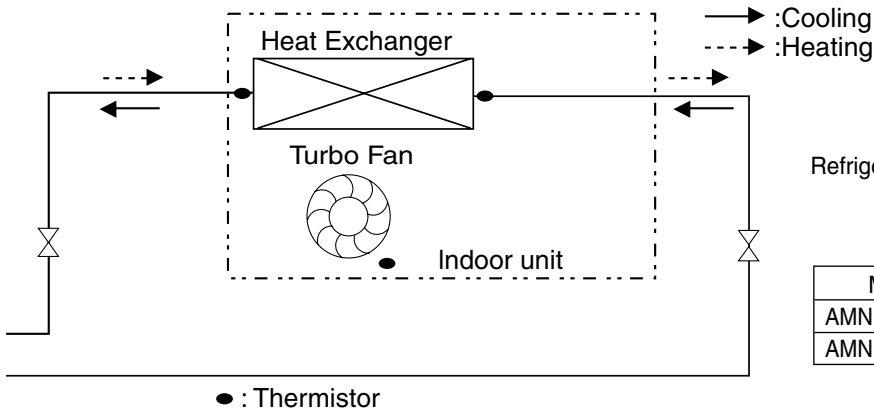

Refrigerant pipe connection port diameter
[unit:mm(inch)]

Model	Gas	Liquid
AMNH096AP*1	Ø9.52(3/8)	Ø6.35(1/4)
AMNH126AP*1		

9. Piping Diagrams

9.2 Outdoor Unit

9.2.1 Cooling Only

A2UC146FA0

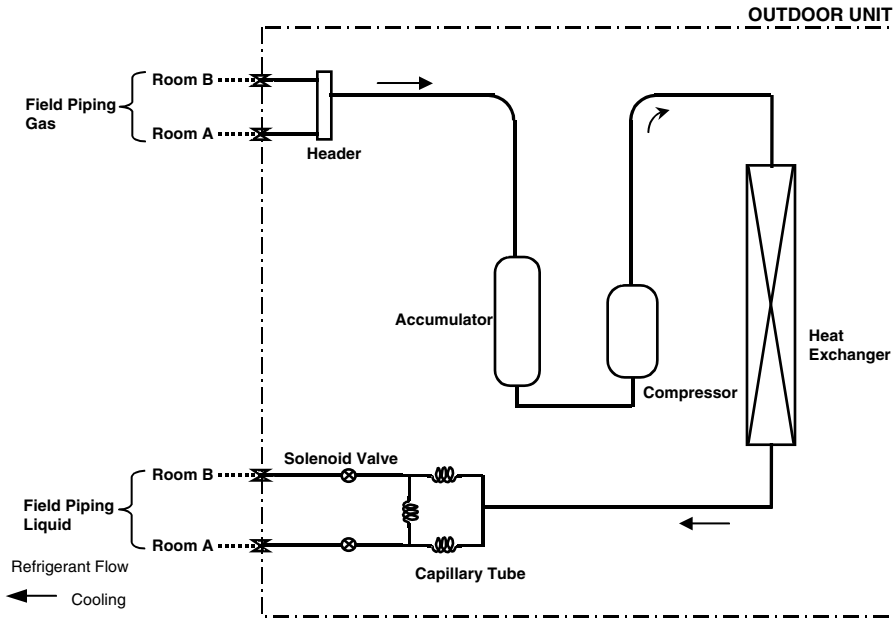

A2UC186FA0

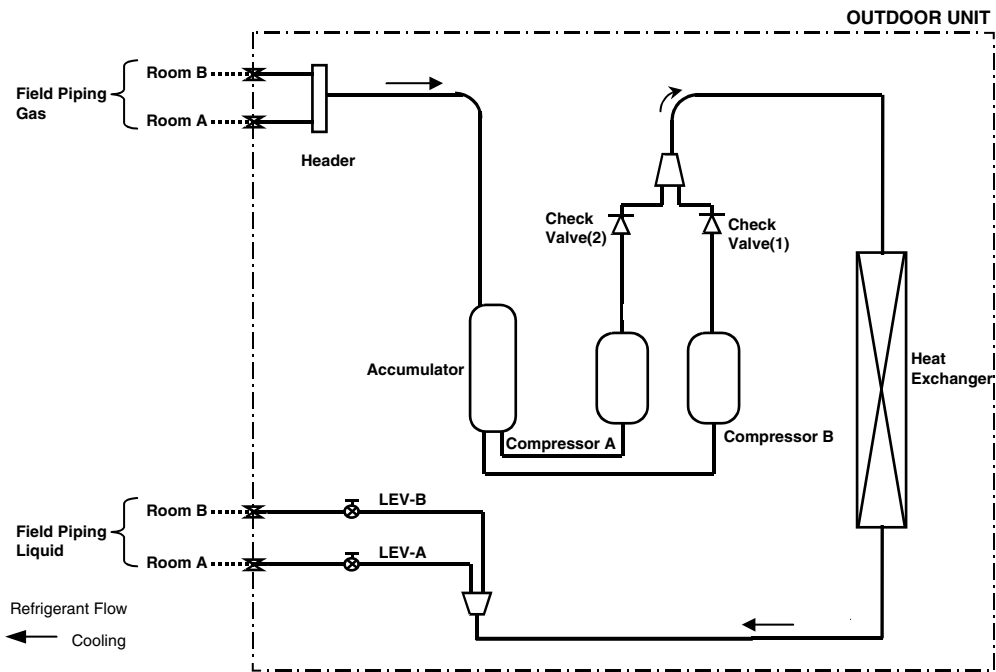



9. Piping Diagrams

A3UC216FA0

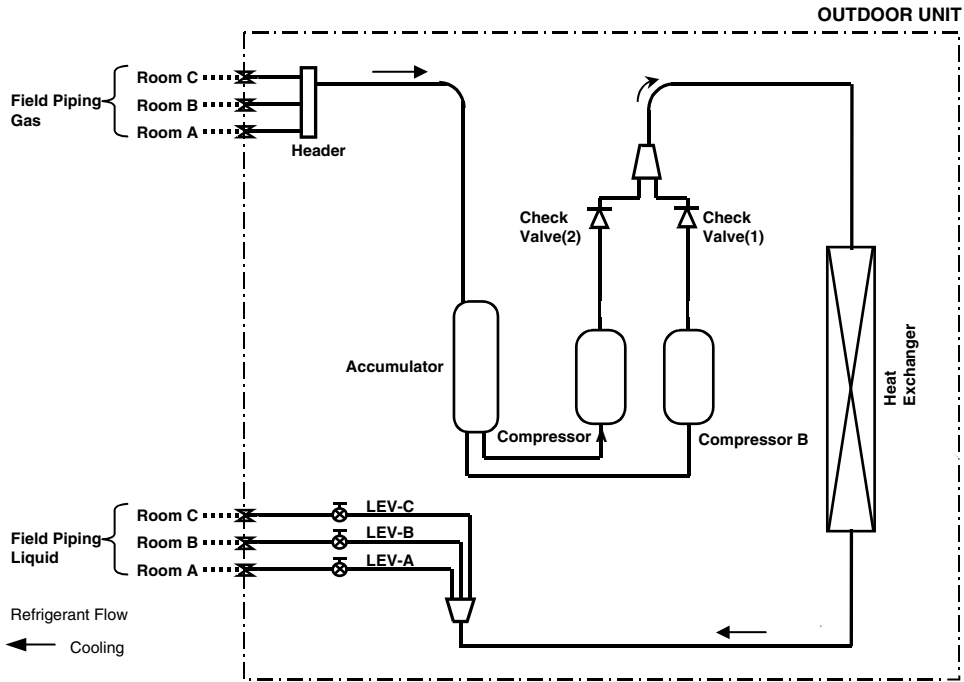

A4UC306FA0

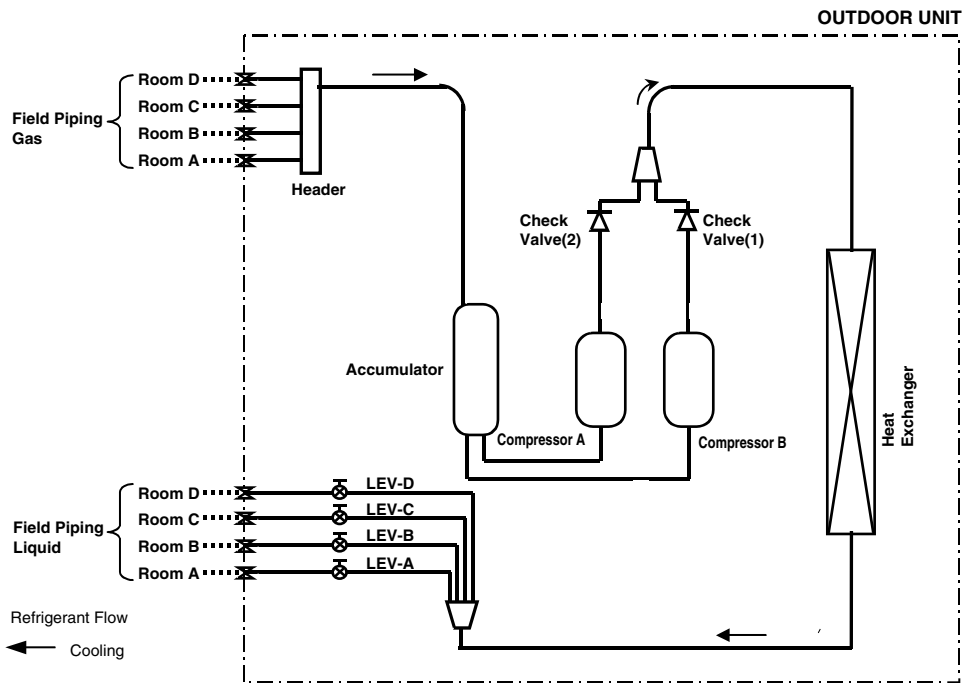

9. Piping Diagrams

9.2.2 Heat Pump

A2UH146FA0

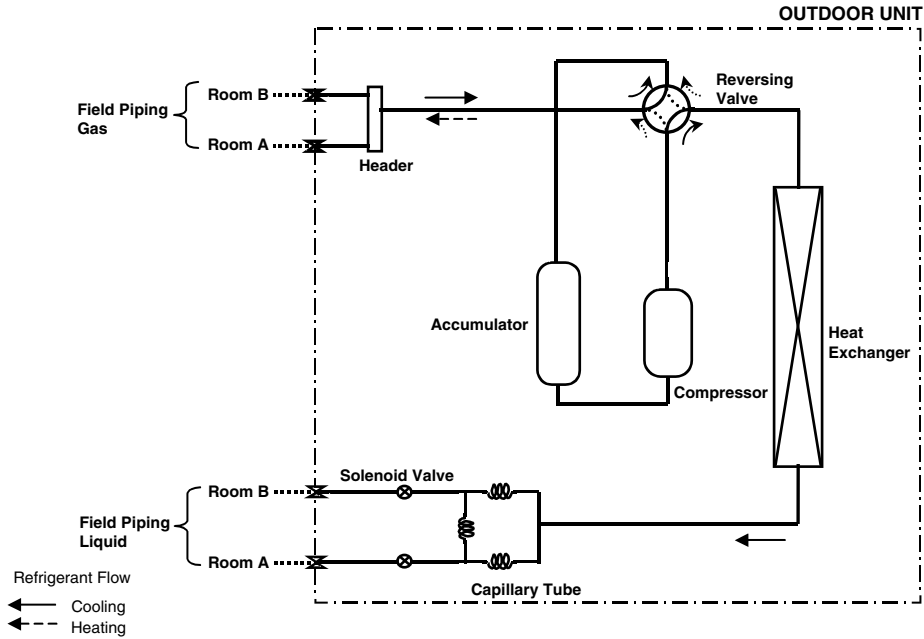

A2UH186FA0

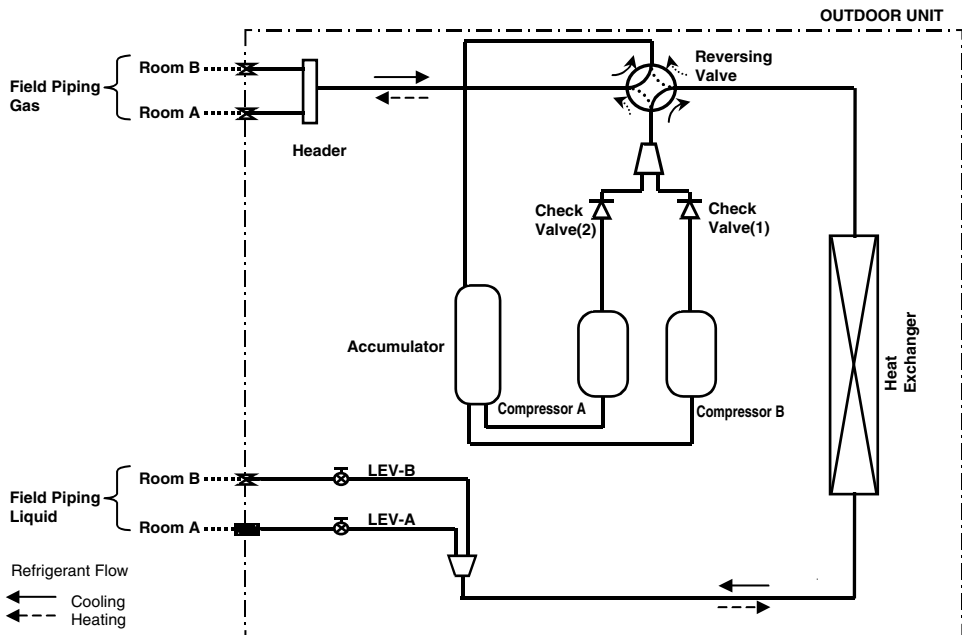



9. Piping Diagrams

A3UH216FA0

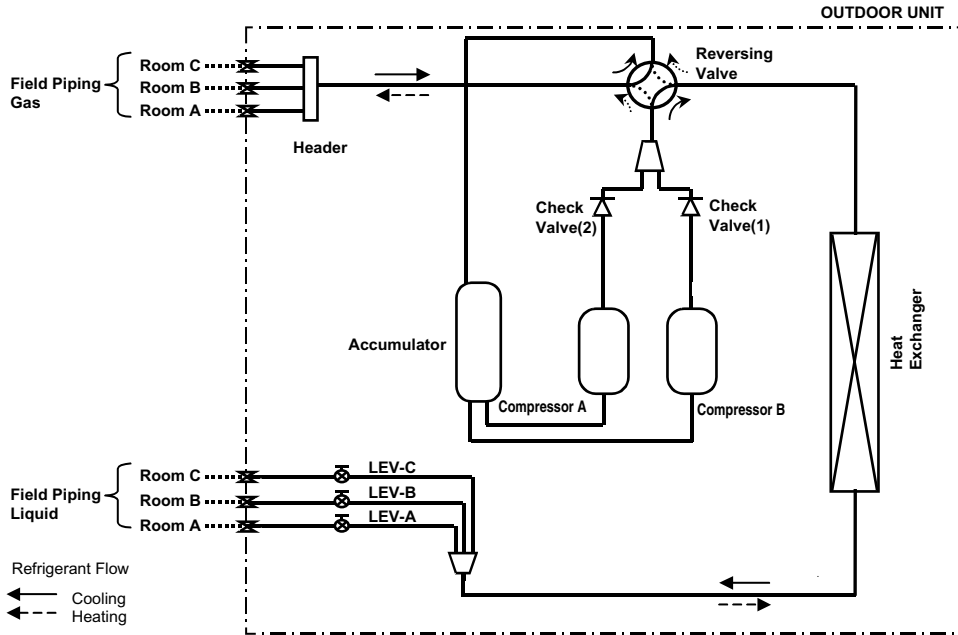

A4UH306FA0

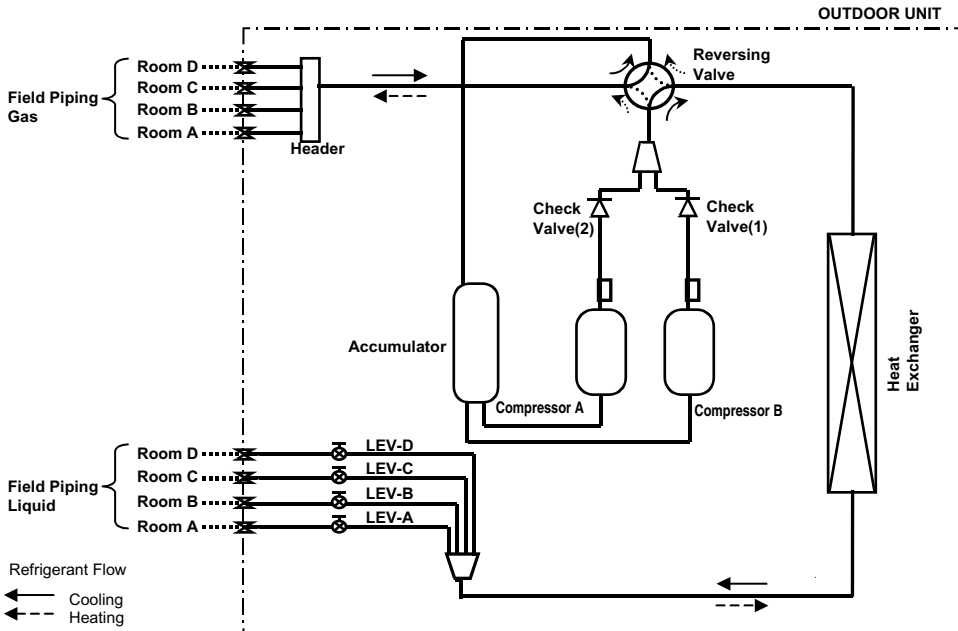

10. Capacity Table

Cooling Only

10.1 A2UC146FA0

[Cooling Capacity]

Combination Capacity Index (kBtu/h)	Outdoor Air Temp.: °CDB	Indoor Air Temp.: °CWB											
		14		16		18		19		22		24	
		TC kW	PI kW	TC kW	PI kW	TC kW	PI kW	TC kW	PI kW	TC kW	PI kW	TC kW	PI kW
7	21	2.52	0.89	2.69	0.90	2.81	0.92	2.91	0.93	3.05	0.95	3.12	0.96
	24	2.48	0.98	2.66	0.99	2.77	1.01	2.87	1.03	3.00	1.04	3.07	1.05
	29	2.39	1.12	2.56	1.14	2.67	1.15	2.76	1.18	2.89	1.19	2.96	1.21
	35	2.28	1.24	2.45	1.26	2.55	1.28	2.64	1.30	2.76	1.32	2.83	1.33
	41	2.16	1.33	2.31	1.35	2.41	1.37	2.50	1.39	2.62	1.41	2.68	1.43
	46	2.02	1.40	2.16	1.43	2.25	1.44	2.33	1.47	2.44	1.49	2.50	1.51
7+7	21	4.19	0.96	4.49	0.97	4.68	0.99	4.84	1.01	5.08	1.02	5.20	1.03
	24	4.13	1.05	4.43	1.07	4.61	1.08	4.78	1.10	5.01	1.12	5.12	1.13
	29	3.98	1.21	4.27	1.23	4.45	1.24	4.60	1.27	4.82	1.28	4.94	1.30
	35	3.80	1.33	4.08	1.36	4.25	1.37	4.40	1.40	4.61	1.42	4.72	1.44
	41	3.60	1.43	3.86	1.45	4.02	1.47	4.16	1.50	4.36	1.52	4.46	1.54
	46	3.36	1.51	3.60	1.54	3.76	1.56	3.89	1.58	4.07	1.61	4.17	1.63

10.2 A2UC186FA0

[Cooling Capacity]

Combination Capacity Index (kBtu/h)	Outdoor Air Temp.: °CDB	Indoor Air Temp.: °CWB											
		14		16		18		19		22		24	
		TC kW	PI kW	TC kW	PI kW	TC kW	PI kW	TC kW	PI kW	TC kW	PI kW	TC kW	PI kW
7	21	1.96	0.53	2.10	0.54	2.18	0.55	2.26	0.56	2.37	0.57	2.42	0.58
	24	1.93	0.59	2.07	0.60	2.15	0.60	2.23	0.62	2.34	0.62	2.39	0.63
	29	1.86	0.67	1.99	0.68	2.07	0.69	2.15	0.71	2.25	0.72	2.30	0.72
	35	1.78	0.74	1.90	0.76	1.98	0.77	2.05	0.78	2.15	0.79	2.20	0.80
	41	1.68	0.80	1.80	0.81	1.88	0.82	1.94	0.83	2.03	0.85	2.08	0.86
	46	1.57	0.84	1.68	0.86	1.75	0.87	1.81	0.88	1.90	0.90	1.95	0.91
9	21	2.66	0.75	2.84	0.77	2.96	0.78	3.07	0.79	3.22	0.80	3.29	0.81
	24	2.62	0.83	2.80	0.84	2.92	0.85	3.02	0.87	3.17	0.88	3.24	0.89
	29	2.52	0.95	2.70	0.96	2.82	0.98	2.91	1.00	3.06	1.01	3.13	1.02
	35	2.41	1.05	2.58	1.07	2.69	1.08	2.78	1.10	2.92	1.12	2.99	1.13
	41	2.28	1.12	2.44	1.14	2.54	1.16	2.63	1.18	2.76	1.19	2.83	1.21
	46	2.13	1.19	2.28	1.21	2.38	1.22	2.46	1.24	2.58	1.26	2.64	1.28
12	21	3.07	0.75	3.29	0.77	3.43	0.78	3.55	0.79	3.72	0.80	3.81	0.81
	24	3.03	0.83	3.25	0.84	3.38	0.85	3.50	0.87	3.67	0.88	3.76	0.89
	29	2.92	0.95	3.13	0.96	3.26	0.98	3.38	1.00	3.54	1.01	3.62	1.02
	35	2.79	1.05	2.99	1.07	3.11	1.08	3.22	1.10	3.38	1.12	3.46	1.13
	41	2.64	1.12	2.83	1.14	2.95	1.16	3.05	1.18	3.20	1.19	3.27	1.21
	46	2.47	1.19	2.64	1.21	2.75	1.22	2.85	1.24	2.99	1.26	3.06	1.28
7+7	21	3.91	1.30	4.19	1.32	4.37	1.34	4.52	1.36	4.74	1.38	4.85	1.40
	24	3.86	1.43	4.13	1.45	4.31	1.47	4.46	1.50	4.67	1.52	4.78	1.54
	29	3.72	1.64	3.98	1.67	4.15	1.69	4.30	1.72	4.50	1.74	4.61	1.76
	35	3.55	1.81	3.80	1.84	3.96	1.87	4.10	1.90	4.30	1.93	4.40	1.95
	41	3.36	1.94	3.60	1.97	3.75	2.00	3.88	2.03	4.07	2.06	4.16	2.09
	46	3.14	2.05	3.36	2.08	3.50	2.11	3.63	2.15	3.80	2.18	3.89	2.21
7+9	21	4.47	1.30	4.79	1.32	4.99	1.34	5.17	1.36	5.42	1.38	5.54	1.40
	24	4.41	1.43	4.72	1.45	4.92	1.47	5.09	1.50	5.34	1.52	5.46	1.54
	29	4.25	1.64	4.55	1.67	4.74	1.69	4.91	1.72	5.15	1.74	5.27	1.76
	35	4.06	1.81	4.35	1.84	4.53	1.87	4.69	1.90	4.91	1.93	5.03	1.95
	41	3.84	1.94	4.11	1.97	4.29	2.00	4.44	2.03	4.65	2.06	4.76	2.09
	46	3.59	2.05	3.84	2.08	4.01	2.11	4.15	2.15	4.35	2.18	4.45	2.21
9+9	21	5.03	1.30	5.39	1.32	5.62	1.34	5.81	1.36	6.09	1.38	6.24	1.40
	24	4.96	1.43	5.31	1.45	5.54	1.47	5.73	1.50	6.01	1.52	6.15	1.54
	29	4.78	1.64	5.12	1.67	5.34	1.69	5.52	1.72	5.79	1.74	5.92	1.76
	35	4.57	1.81	4.89	1.84	5.10	1.87	5.28	1.90	5.53	1.93	5.66	1.95
	41	4.32	1.94	4.63	1.97	4.82	2.00	4.99	2.03	5.23	2.06	5.35	2.09
	46	4.04	2.05	4.32	2.08	4.51	2.11	4.66	2.15	4.89	2.18	5.00	2.21
7+12	21	5.03	1.30	5.39	1.32	5.62	1.34	5.81	1.36	6.09	1.38	6.24	1.40
	24	4.96	1.43	5.31	1.45	5.54	1.47	5.73	1.50	6.01	1.52	6.15	1.54
	29	4.78	1.64	5.12	1.67	5.34	1.69	5.52	1.72	5.79	1.74	5.92	1.76
	35	4.57	1.81	4.89	1.84	5.10	1.87	5.28	1.90	5.53	1.93	5.66	1.95
	41	4.32	1.94	4.63	1.97	4.82	2.00	4.99	2.03	5.23	2.06	5.35	2.09
	46	4.04	2.05	4.32	2.08	4.51	2.11	4.66	2.15	4.89	2.18	5.00	2.21

Notes:

1. Capacities are based on the following conditions.
Corresponding refrigerant piping length : 7.5m
Level difference : 0m

2. TC : Total Capacity (kW)
PI : Power Input (kW)



10. Capacity Table

Cooling Only

10.3 A3UC216FA0

[Cooling Capacity]

Combination Capacity Index (kBtu/h)	Outdoor Air Temp.: °CDB	Indoor Air Temp.: °CWB											
		14		16		18		19		22		24	
		TC kW	PI kW	TC kW	PI kW	TC kW	PI kW	TC kW	PI kW	TC kW	PI kW	TC kW	PI kW
7	21	2.24	0.60	2.40	0.61	2.50	0.62	2.58	0.63	2.71	0.64	2.77	0.65
	24	2.20	0.66	2.36	0.67	2.46	0.68	2.55	0.69	2.67	0.70	2.73	0.71
	29	2.12	0.76	2.28	0.77	2.37	0.78	2.45	0.80	2.57	0.81	2.63	0.82
	35	2.03	0.84	2.17	0.85	2.26	0.86	2.34	0.88	2.46	0.89	2.51	0.90
	41	1.92	0.90	2.06	0.91	2.14	0.92	2.22	0.94	2.33	0.96	2.38	0.97
	46	1.79	0.95	1.92	0.97	2.00	0.98	2.07	1.00	2.17	1.01	2.22	1.02
9	21	2.66	0.62	2.84	0.63	2.96	0.63	3.07	0.65	3.22	0.66	3.29	0.66
	24	2.62	0.68	2.80	0.69	2.92	0.70	3.02	0.71	3.17	0.72	3.24	0.73
	29	2.52	0.78	2.70	0.79	2.82	0.80	2.91	0.81	3.06	0.83	3.13	0.84
	35	2.41	0.86	2.58	0.87	2.69	0.88	2.78	0.90	2.92	0.91	2.99	0.92
	41	2.28	0.92	2.44	0.93	2.54	0.95	2.63	0.96	2.76	0.98	2.83	0.99
	46	2.13	0.97	2.28	0.99	2.38	1.00	2.46	1.02	2.58	1.03	2.64	1.05
12(ART COOL)	21	3.07	0.79	3.29	0.80	3.43	0.81	3.55	0.83	3.72	0.84	3.81	0.85
	24	3.03	0.86	3.25	0.88	3.38	0.89	3.50	0.91	3.67	0.92	3.76	0.93
	29	2.92	0.99	3.13	1.01	3.26	1.02	3.38	1.04	3.54	1.06	3.62	1.07
	35	2.79	1.10	2.99	1.11	3.11	1.13	3.22	1.15	3.38	1.17	3.46	1.18
	41	2.64	1.17	2.83	1.19	2.95	1.21	3.05	1.23	3.20	1.25	3.27	1.26
	46	2.47	1.24	2.64	1.26	2.75	1.28	2.85	1.30	2.99	1.32	3.06	1.34
12	21	3.35	0.79	3.59	0.80	3.74	0.81	3.88	0.83	4.06	0.84	4.16	0.85
	24	3.31	0.86	3.54	0.88	3.69	0.89	3.82	0.91	4.00	0.92	4.10	0.93
	29	3.19	0.99	3.41	1.01	3.56	1.02	3.68	1.04	3.86	1.06	3.95	1.07
	35	3.04	1.10	3.26	1.11	3.40	1.13	3.52	1.15	3.69	1.17	3.77	1.18
	41	2.88	1.17	3.08	1.19	3.21	1.21	3.33	1.23	3.49	1.25	3.57	1.26
	46	2.69	1.24	2.88	1.26	3.00	1.28	3.11	1.30	3.26	1.32	3.34	1.34
7+7	21	4.70	1.44	5.03	1.46	5.24	1.48	5.43	1.51	5.69	1.53	5.82	1.55
	24	4.63	1.58	4.96	1.61	5.17	1.63	5.35	1.66	5.61	1.68	5.74	1.70
	29	4.46	1.81	4.78	1.84	4.98	1.86	5.15	1.90	5.40	1.93	5.53	1.95
	35	4.26	2.00	4.56	2.04	4.76	2.06	4.92	2.10	5.16	2.13	5.28	2.16
	41	4.03	2.14	4.32	2.18	4.50	2.21	4.66	2.25	4.88	2.28	5.00	2.31
	46	3.77	2.26	4.04	2.30	4.21	2.33	4.35	2.38	4.56	2.41	4.67	2.44
7+9	21	5.03	1.44	5.39	1.46	5.62	1.48	5.81	1.51	6.09	1.53	6.24	1.55
	24	4.96	1.58	5.31	1.61	5.54	1.63	5.73	1.66	6.01	1.68	6.15	1.70
	29	4.78	1.81	5.12	1.84	5.34	1.86	5.52	1.90	5.79	1.93	5.92	1.95
	35	4.57	2.00	4.89	2.04	5.10	2.06	5.28	2.10	5.53	2.13	5.66	2.16
	41	4.32	2.14	4.63	2.18	4.82	2.21	4.99	2.25	5.23	2.28	5.35	2.31
	46	4.04	2.26	4.32	2.30	4.51	2.33	4.66	2.38	4.89	2.41	5.00	2.44
9+9	21	5.31	1.44	5.69	1.46	5.93	1.48	6.14	1.51	6.43	1.53	6.58	1.55
	24	5.24	1.58	5.61	1.61	5.84	1.63	6.05	1.66	6.34	1.68	6.49	1.70
	29	5.05	1.81	5.40	1.84	5.63	1.86	5.83	1.90	6.11	1.93	6.25	1.95
	35	4.82	2.00	5.16	2.04	5.38	2.06	5.57	2.10	5.84	2.13	5.97	2.16
	41	4.56	2.14	4.88	2.18	5.09	2.21	5.27	2.25	5.52	2.28	5.65	2.31
	46	4.26	2.26	4.56	2.30	4.76	2.33	4.92	2.38	5.16	2.41	5.28	2.44
7+12(ART COOL)	21	5.31	1.44	5.69	1.46	5.93	1.48	6.14	1.51	6.43	1.53	6.58	1.55
	24	5.24	1.58	5.61	1.61	5.84	1.63	6.05	1.66	6.34	1.68	6.49	1.70
	29	5.05	1.81	5.40	1.84	5.63	1.86	5.83	1.90	6.11	1.93	6.25	1.95
	35	4.82	2.00	5.16	2.04	5.38	2.06	5.57	2.10	5.84	2.13	5.97	2.16
	41	4.56	2.14	4.88	2.18	5.09	2.21	5.27	2.25	5.52	2.28	5.65	2.31
	46	4.26	2.26	4.56	2.30	4.76	2.33	4.92	2.38	5.16	2.41	5.28	2.44
7+12	21	5.59	1.44	5.99	1.46	6.24	1.48	6.46	1.51	6.77	1.53	6.93	1.55
	24	5.51	1.58	5.90	1.61	6.15	1.63	6.37	1.66	6.67	1.68	6.83	1.70
	29	5.31	1.81	5.69	1.84	5.93	1.86	6.14	1.90	6.43	1.93	6.58	1.95
	35	5.07	2.00	5.43	2.04	5.66	2.06	5.86	2.10	6.14	2.13	6.29	2.16
	41	4.80	2.14	5.14	2.18	5.36	2.21	5.55	2.25	5.81	2.28	5.95	2.31
	46	4.49	2.26	4.80	2.30	5.01	2.33	5.18	2.38	5.43	2.41	5.56	2.44
9+12	21	5.87	1.44	6.29	1.46	6.55	1.48	6.78	1.51	7.11	1.53	7.27	1.55
	24	5.79	1.58	6.20	1.61	6.46	1.63	6.69	1.66	7.01	1.68	7.17	1.70
	29	5.58	1.81	5.97	1.84	6.22	1.86	6.44	1.90	6.75	1.93	6.91	1.95
	35	5.33	2.00	5.71	2.04	5.95	2.06	6.15	2.10	6.45	2.13	6.60	2.16
	41	5.04	2.14	5.40	2.18	5.63	2.21	5.82	2.25	6.10	2.28	6.25	2.31
	46	4.71	2.26	5.04	2.30	5.26	2.33	5.44	2.38	5.70	2.41	5.84	2.44
7+7+7	21	5.87	1.44	6.29	1.46	6.55	1.48	6.78	1.51	7.11	1.53	7.27	1.55
	24	5.79	1.58	6.20	1.61	6.46	1.63	6.69	1.66	7.01	1.68	7.17	1.70
	29	5.58	1.81	5.97	1.84	6.22	1.86	6.44	1.90	6.75	1.93	6.91	1.95
	35	5.33	2.00	5.71	2.04	5.95	2.06	6.15	2.10	6.45	2.13	6.60	2.16
	41	5.04	2.14	5.40	2.18	5.63	2.21	5.82	2.25	6.10	2.28	6.25	2.31
	46	4.71	2.26	5.04	2.30	5.26	2.33	5.44	2.38	5.70	2.41	5.84	2.44
7+7+9	21	5.87	1.44	6.29	1.46	6.55	1.48	6.78	1.51	7.11	1.53	7.27	1.55
	24	5.79	1.58	6.20	1.61	6.46	1.63	6.69	1.66	7.01	1.68	7.17	1.70
	29	5.58	1.81	5.97	1.84	6.22	1.86	6.44	1.90	6.75	1.93	6.91	1.95
	35	5.33	2.00	5.71	2.04	5.95	2.06	6.15	2.10	6.45	2.13	6.60	2.16
	41	5.04	2.14	5.40	2.18	5.63	2.21	5.82	2.25	6.10	2.28	6.25	2.31
	46	4.71	2.26	5.04	2.30	5.26	2.33	5.44	2.38	5.70	2.41	5.84	2.44

Notes:

1. Capacities are based on the following conditions.
 Corresponding refrigerant piping length : 7.5m
 Level difference : 0m

2. TC : Total Capacity (kW)
 PI : Power Input (kW)

10. Capacity Table

Cooling Only

10.4 A4UC306FA0

[Cooling Capacity]

Combination Capacity Index (kBtu/h)	Outdoor Air Temp.: °CDB	Indoor Air Temp.: °CWB											
		14		16		18		19		22		24	
		TC kW	PI kW	TC kW	PI kW	TC kW	PI kW	TC kW	PI kW	TC kW	PI kW	TC kW	PI kW
7	21	2.52	0.82	2.69	0.84	2.81	0.85	2.91	0.86	3.05	0.87	3.12	0.88
	24	2.48	0.90	2.66	0.92	2.77	0.93	2.87	0.95	3.00	0.96	3.07	0.97
	29	2.39	1.03	2.56	1.05	2.67	1.07	2.76	1.09	2.89	1.10	2.96	1.11
	35	2.28	1.14	2.45	1.16	2.55	1.18	2.64	1.20	2.76	1.22	2.83	1.23
	41	2.16	1.22	2.31	1.25	2.41	1.26	2.50	1.28	2.62	1.30	2.68	1.32
	46	2.02	1.29	2.16	1.32	2.25	1.33	2.33	1.36	2.44	1.38	2.50	1.39
9	21	2.80	0.82	2.99	0.84	3.12	0.85	3.23	0.86	3.39	0.87	3.46	0.88
	24	2.76	0.90	2.95	0.92	3.08	0.93	3.18	0.95	3.34	0.96	3.41	0.97
	29	2.66	1.03	2.84	1.05	2.96	1.07	3.07	1.09	3.22	1.10	3.29	1.11
	35	2.54	1.14	2.72	1.16	2.83	1.18	2.93	1.20	3.07	1.22	3.14	1.23
	41	2.40	1.22	2.57	1.25	2.68	1.26	2.77	1.28	2.91	1.30	2.97	1.32
	46	2.24	1.29	2.40	1.32	2.50	1.33	2.59	1.36	2.72	1.38	2.78	1.39
12	21	3.35	0.82	3.59	0.84	3.74	0.85	3.88	0.86	4.06	0.87	4.16	0.88
	24	3.31	0.90	3.54	0.92	3.69	0.93	3.82	0.95	4.00	0.96	4.10	0.97
	29	3.19	1.03	3.41	1.05	3.56	1.07	3.68	1.09	3.86	1.10	3.95	1.11
	35	3.04	1.14	3.26	1.16	3.40	1.18	3.52	1.20	3.69	1.22	3.77	1.23
	41	2.88	1.22	3.08	1.25	3.21	1.26	3.33	1.28	3.49	1.30	3.57	1.32
	46	2.69	1.29	2.88	1.32	3.00	1.33	3.11	1.36	3.26	1.38	3.34	1.39
18	21	5.03	1.33	5.39	1.36	5.62	1.37	5.81	1.40	6.09	1.42	6.24	1.44
	24	4.96	1.47	5.31	1.49	5.54	1.51	5.73	1.54	6.01	1.56	6.15	1.58
	29	4.78	1.68	5.12	1.71	5.34	1.73	5.52	1.76	5.79	1.79	5.92	1.81
	35	4.57	1.86	4.89	1.89	5.10	1.91	5.28	1.95	5.53	1.98	5.66	2.00
	41	4.32	1.99	4.63	2.02	4.82	2.05	4.99	2.09	5.23	2.12	5.35	2.14
	46	4.04	2.10	4.32	2.14	4.51	2.17	4.66	2.21	4.89	2.24	5.00	2.27
24	21	6.71	2.22	7.19	2.26	7.49	2.29	7.75	2.33	8.12	2.37	8.31	2.40
	24	6.61	2.44	7.08	2.48	7.38	2.52	7.64	2.56	8.01	2.60	8.20	2.63
	29	6.37	2.80	6.83	2.85	7.11	2.89	7.36	2.94	7.72	2.98	7.90	3.02
	35	6.09	3.10	6.52	3.15	6.79	3.19	7.03	3.25	7.37	3.30	7.54	3.34
	41	5.76	3.32	6.17	3.37	6.43	3.42	6.65	3.48	6.98	3.53	7.14	3.57
	46	5.38	3.51	5.77	3.57	6.01	3.61	6.22	3.68	6.52	3.73	6.67	3.78
7+7	21	4.47	1.33	4.79	1.36	4.99	1.37	5.17	1.40	5.42	1.42	5.54	1.44
	24	4.41	1.47	4.72	1.49	4.92	1.51	5.09	1.54	5.34	1.56	5.46	1.58
	29	4.25	1.68	4.55	1.71	4.74	1.73	4.91	1.76	5.15	1.79	5.27	1.81
	35	4.06	1.86	4.35	1.89	4.53	1.91	4.69	1.95	4.91	1.98	5.03	2.00
	41	3.84	1.99	4.11	2.02	4.29	2.05	4.44	2.09	4.65	2.12	4.76	2.14
	46	3.59	2.10	3.84	2.14	4.01	2.17	4.15	2.21	4.35	2.24	4.45	2.27
7+9	21	4.75	1.33	5.09	1.36	5.30	1.37	5.49	1.40	5.75	1.42	5.89	1.44
	24	4.68	1.47	5.02	1.49	5.23	1.51	5.41	1.54	5.67	1.56	5.81	1.58
	29	4.51	1.68	4.84	1.71	5.04	1.73	5.22	1.76	5.47	1.79	5.59	1.81
	35	4.31	1.86	4.62	1.89	4.81	1.91	4.98	1.95	5.22	1.98	5.34	2.00
	41	4.08	1.99	4.37	2.02	4.55	2.05	4.71	2.09	4.94	2.12	5.06	2.14
	46	3.81	2.10	4.08	2.14	4.26	2.17	4.41	2.21	4.62	2.24	4.73	2.27
7+12	21	5.31	1.33	5.69	1.36	5.93	1.37	6.14	1.40	6.43	1.42	6.58	1.44
	24	5.24	1.47	5.61	1.49	5.84	1.51	6.05	1.54	6.34	1.56	6.49	1.58
	29	5.05	1.68	5.40	1.71	5.63	1.73	5.83	1.76	6.11	1.79	6.25	1.81
	35	4.82	1.86	5.16	1.89	5.38	1.91	5.57	1.95	5.84	1.98	5.97	2.00
	41	4.56	1.99	4.88	2.02	5.09	2.05	5.27	2.09	5.52	2.12	5.65	2.14
	46	4.26	2.10	4.56	2.14	4.76	2.17	4.92	2.21	5.16	2.24	5.28	2.27
7+18	21	5.03	2.22	5.39	2.26	5.62	2.29	5.81	2.33	6.09	2.37	6.24	2.40
	24	4.96	2.44	5.31	2.48	5.54	2.52	5.73	2.56	6.01	2.60	6.15	2.63
	29	4.78	2.80	5.12	2.85	5.34	2.89	5.52	2.94	5.79	2.98	5.92	3.02
	35	4.57	3.10	4.89	3.15	5.10	3.19	5.28	3.25	5.53	3.30	5.66	3.34
	41	4.32	3.32	4.63	3.37	4.82	3.42	4.99	3.48	5.23	3.53	5.35	3.57
	46	4.04	3.51	4.32	3.57	4.51	3.61	4.66	3.68	4.89	3.73	5.00	3.78
7+24	21	8.39	2.22	8.98	2.26	9.36	2.29	9.69	2.33	10.16	2.37	10.39	2.40
	24	8.27	2.44	8.85	2.48	9.23	2.52	9.55	2.56	10.01	2.60	10.24	2.63
	29	7.97	2.80	8.53	2.85	8.89	2.89	9.20	2.94	9.65	2.98	9.87	3.02
	35	7.61	3.10	8.15	3.15	8.49	3.19	8.79	3.25	9.22	3.30	9.43	3.34
	41	7.20	3.32	7.71	3.37	8.04	3.42	8.32	3.48	8.72	3.53	8.92	3.57
	46	6.73	3.51	7.21	3.57	7.51	3.61	7.77	3.68	8.15	3.73	8.34	3.78
9+9	21	5.03	1.33	5.39	1.36	5.62	1.37	5.81	1.40	6.09	1.42	6.24	1.44
	24	4.96	1.47	5.31	1.49	5.54	1.51	5.73	1.54	6.01	1.56	6.15	1.58
	29	4.78	1.68	5.12	1.71	5.34	1.73	5.52	1.76	5.79	1.79	5.92	1.81
	35	4.57	1.86	4.89	1.89	5.10	1.91	5.28	1.95	5.53	1.98	5.66	2.00
	41	4.32	1.99	4.63	2.02	4.82	2.05	4.99	2.09	5.23	2.12	5.35	2.14
	46	4.04	2.10	4.32	2.14	4.51	2.17	4.66	2.21	4.89	2.24	5.00	2.27
9+12	21	6.99	2.22	7.48	2.26	7.80	2.29	8.07	2.33	8.46	2.37	8.66	2.40
	24	6.89	2.44	7.38	2.48	7.69	2.52	7.96	2.56	8.34	2.60	8.54	2.63
	29	6.64	2.80	7.11	2.85	7.41	2.89	7.67	2.94	8.04	2.98	8.23	3.02
	35	6.34	3.10	6.79	3.15	7.08	3.19	7.33	3.25	7.68	3.30	7.86	3.34
	41	6.00	3.32	6.43	3.37	6.70	3.42	6.93	3.48	7.27	3.53	7.44	3.57
	46	5.61	3.51	6.01	3.57	6.26	3.61	6.48	3.68	6.79	3.73	6.95	3.78



10. Capacity Table

Cooling Only

Combination Capacity Index (kBTu/h)	Outdoor Air Temp.: °CDB	Indoor Air Temp.: °CWB											
		14		16		18		19		22		24	
		TC kW	PI kW	TC kW	PI kW	TC kW	PI kW	TC kW	PI kW	TC kW	PI kW	TC kW	PI kW
9+18	21	7.83	2.22	8.38	2.26	8.74	2.29	9.04	2.33	9.48	2.37	9.70	2.40
	24	7.72	2.44	8.26	2.48	8.61	2.52	8.91	2.56	9.34	2.60	9.56	2.63
	29	7.44	2.80	7.96	2.85	8.30	2.89	8.59	2.94	9.00	2.98	9.21	3.02
	35	7.10	3.10	7.61	3.15	7.93	3.19	8.21	3.25	8.60	3.30	8.80	3.34
	41	6.72	3.32	7.20	3.37	7.50	3.42	7.76	3.48	8.14	3.53	8.33	3.57
9+24	46	6.28	3.51	6.73	3.57	7.01	3.61	7.26	3.68	7.60	3.73	7.78	3.78
	21	8.39	2.22	8.98	2.26	9.36	2.29	9.69	2.33	10.16	2.37	10.39	2.40
	24	8.27	2.44	8.85	2.48	9.23	2.52	9.55	2.56	10.01	2.60	10.24	2.63
	29	7.97	2.80	8.53	2.85	8.89	2.89	9.20	2.94	9.65	2.98	9.87	3.02
	35	7.61	3.10	8.15	3.15	8.49	3.19	8.79	3.25	9.22	3.30	9.43	3.34
12+12	41	7.20	3.32	7.71	3.37	8.04	3.42	8.32	3.48	8.72	3.53	8.92	3.57
	46	6.73	3.51	7.21	3.57	7.51	3.61	7.77	3.68	8.15	3.73	8.34	3.78
	21	7.27	2.22	7.78	2.26	8.11	2.29	8.40	2.33	8.80	2.37	9.01	2.40
	24	7.16	2.44	7.67	2.48	8.00	2.52	8.28	2.56	8.68	2.60	8.88	2.63
	29	6.90	2.80	7.40	2.85	7.71	2.89	7.98	2.94	8.36	2.98	8.56	3.02
12+18	35	6.59	3.10	7.06	3.15	7.36	3.19	7.62	3.25	7.99	3.30	8.17	3.34
	41	6.24	3.32	6.68	3.37	6.96	3.42	7.21	3.48	7.56	3.53	7.73	3.57
	46	5.83	3.51	6.25	3.57	6.51	3.61	6.74	3.68	7.06	3.73	7.23	3.78
	21	8.39	2.22	8.98	2.26	9.36	2.29	9.69	2.33	10.16	2.37	10.39	2.40
	24	8.27	2.44	8.85	2.48	9.23	2.52	9.55	2.56	10.01	2.60	10.24	2.63
7+7+7	29	7.97	2.80	8.53	2.85	8.89	2.89	9.20	2.94	9.65	2.98	9.87	3.02
	35	7.61	3.10	8.15	3.15	8.49	3.19	8.79	3.25	9.22	3.30	9.43	3.34
	41	7.20	3.32	7.71	3.37	8.04	3.42	8.32	3.48	8.72	3.53	8.92	3.57
	46	6.73	3.51	7.21	3.57	7.51	3.61	7.77	3.68	8.15	3.73	8.34	3.78
	21	7.55	2.22	8.08	2.26	8.42	2.29	8.72	2.33	9.14	2.37	9.35	2.40
7+7+9	24	7.44	2.44	7.97	2.48	8.30	2.52	8.60	2.56	9.01	2.60	9.22	2.63
	29	7.17	2.80	7.68	2.85	8.00	2.89	8.28	2.94	8.68	2.98	8.89	3.02
	35	6.85	3.10	7.34	3.15	7.64	3.19	7.91	3.25	8.29	3.30	8.49	3.34
	41	6.48	3.32	6.94	3.37	7.23	3.42	7.49	3.48	7.85	3.53	8.03	3.57
	46	6.06	3.51	6.49	3.57	6.76	3.61	7.00	3.68	7.33	3.73	7.50	3.78
7+7+12	21	8.11	2.22	8.68	2.26	9.05	2.29	9.37	2.33	9.82	2.37	10.05	2.40
	24	7.99	2.44	8.56	2.48	8.92	2.52	9.23	2.56	9.68	2.60	9.90	2.63
	29	7.70	2.80	8.25	2.85	8.60	2.89	8.90	2.94	9.33	2.98	9.54	3.02
	35	7.36	3.10	7.88	3.15	8.21	3.19	8.50	3.25	8.91	3.30	9.12	3.34
	41	6.96	3.32	7.45	3.37	7.77	3.42	8.04	3.48	8.43	3.53	8.63	3.57
7+7+18	46	6.50	3.51	6.97	3.57	7.26	3.61	7.51	3.68	7.88	3.73	8.06	3.78
	21	7.83	2.22	8.38	2.26	8.74	2.29	9.04	2.33	9.48	2.37	9.70	2.40
	24	7.72	2.44	8.26	2.48	8.61	2.52	8.91	2.56	9.34	2.60	9.56	2.63
	29	7.44	2.80	7.96	2.85	8.30	2.89	8.59	2.94	9.00	2.98	9.21	3.02
	35	7.10	3.10	7.61	3.15	7.93	3.19	8.21	3.25	8.60	3.30	8.80	3.34
7+9+9	41	6.72	3.32	7.20	3.37	7.50	3.42	7.76	3.48	8.14	3.53	8.33	3.57
	46	6.28	3.51	6.73	3.57	7.01	3.61	7.26	3.68	7.60	3.73	7.78	3.78
	21	8.39	2.22	8.98	2.26	9.36	2.29	9.69	2.33	10.16	2.37	10.39	2.40
	24	8.27	2.44	8.85	2.48	9.23	2.52	9.55	2.56	10.01	2.60	10.24	2.63
	29	7.97	2.80	8.53	2.85	8.89	2.89	9.20	2.94	9.65	2.98	9.87	3.02
7+9+12	35	7.61	3.10	8.15	3.15	8.49	3.19	8.79	3.25	9.22	3.30	9.43	3.34
	41	7.20	3.32	7.71	3.37	8.04	3.42	8.32	3.48	8.72	3.53	8.92	3.57
	46	6.73	3.51	7.21	3.57	7.51	3.61	7.77	3.68	8.15	3.73	8.34	3.78
	21	8.11	2.22	8.68	2.26	9.05	2.29	9.37	2.33	9.82	2.37	10.05	2.40
	24	7.99	2.44	8.56	2.48	8.92	2.52	9.23	2.56	9.68	2.60	9.90	2.63
7+12+12	29	7.70	2.80	8.25	2.85	8.60	2.89	8.90	2.94	9.33	2.98	9.54	3.02
	35	7.36	3.10	7.88	3.15	8.21	3.19	8.50	3.25	8.91	3.30	9.12	3.34
	41	6.96	3.32	7.45	3.37	7.77	3.42	8.04	3.48	8.43	3.53	8.63	3.57
	46	6.50	3.51	6.97	3.57	7.26	3.61	7.51	3.68	7.88	3.73	8.06	3.78
	21	8.39	2.22	8.98	2.26	9.36	2.29	9.69	2.33	10.16	2.37	10.39	2.40
9+9+9	24	8.27	2.44	8.85	2.48	9.23	2.52	9.55	2.56	10.01	2.60	10.24	2.63
	29	7.97	2.80	8.53	2.85	8.89	2.89	9.20	2.94	9.65	2.98	9.87	3.02
	35	7.61	3.10	8.15	3.15	8.49	3.19	8.79	3.25	9.22	3.30	9.43	3.34
	41	7.20	3.32	7.71	3.37	8.04	3.42	8.32	3.48	8.72	3.53	8.92	3.57
	46	6.73	3.51	7.21	3.57	7.51	3.61	7.77	3.68	8.15	3.73	8.34	3.78

10. Capacity Table

Cooling Only

Combination Capacity Index (kBtu/h)	Outdoor Air Temp.: °CDB	Indoor Air Temp.: °CWB											
		14		16		18		19		22		24	
		TC kW	PI kW	TC kW	PI kW	TC kW	PI kW	TC kW	PI kW	TC kW	PI kW	TC kW	PI kW
9+9+12	21	8.39	2.22	8.98	2.26	9.36	2.29	9.69	2.33	10.16	2.37	10.39	2.40
	24	8.27	2.44	8.85	2.48	9.23	2.52	9.55	2.56	10.01	2.60	10.24	2.63
	29	7.97	2.80	8.53	2.85	8.89	2.89	9.20	2.94	9.65	2.98	9.87	3.02
	35	7.61	3.10	8.15	3.15	8.49	3.19	8.79	3.25	9.22	3.30	9.43	3.34
	41	7.20	3.32	7.71	3.37	8.04	3.42	8.32	3.48	8.72	3.53	8.92	3.57
9+12+12	21	8.39	2.22	8.98	2.26	9.36	2.29	9.69	2.33	10.16	2.37	10.39	2.40
	24	8.27	2.44	8.85	2.48	9.23	2.52	9.55	2.56	10.01	2.60	10.24	2.63
	29	7.97	2.80	8.53	2.85	8.89	2.89	9.20	2.94	9.65	2.98	9.87	3.02
	35	7.61	3.10	8.15	3.15	8.49	3.19	8.79	3.25	9.22	3.30	9.43	3.34
	41	7.20	3.32	7.71	3.37	8.04	3.42	8.32	3.48	8.72	3.53	8.92	3.57
7+7+7+7	21	8.39	2.22	8.98	2.26	9.36	2.29	9.69	2.33	10.16	2.37	10.39	2.40
	24	8.27	2.44	8.85	2.48	9.23	2.52	9.55	2.56	10.01	2.60	10.24	2.63
	29	7.97	2.80	8.53	2.85	8.89	2.89	9.20	2.94	9.65	2.98	9.87	3.02
	35	7.61	3.10	8.15	3.15	8.49	3.19	8.79	3.25	9.22	3.30	9.43	3.34
	41	7.20	3.32	7.71	3.37	8.04	3.42	8.32	3.48	8.72	3.53	8.92	3.57
7+7+7+9	21	8.39	2.22	8.98	2.26	9.36	2.29	9.69	2.33	10.16	2.37	10.39	2.40
	24	8.27	2.44	8.85	2.48	9.23	2.52	9.55	2.56	10.01	2.60	10.24	2.63
	29	7.97	2.80	8.53	2.85	8.89	2.89	9.20	2.94	9.65	2.98	9.87	3.02
	35	7.61	3.10	8.15	3.15	8.49	3.19	8.79	3.25	9.22	3.30	9.43	3.34
	41	7.20	3.32	7.71	3.37	8.04	3.42	8.32	3.48	8.72	3.53	8.92	3.57
7+7+7+12	21	8.39	2.22	8.98	2.26	9.36	2.29	9.69	2.33	10.16	2.37	10.39	2.40
	24	8.27	2.44	8.85	2.48	9.23	2.52	9.55	2.56	10.01	2.60	10.24	2.63
	29	7.97	2.80	8.53	2.85	8.89	2.89	9.20	2.94	9.65	2.98	9.87	3.02
	35	7.61	3.10	8.15	3.15	8.49	3.19	8.79	3.25	9.22	3.30	9.43	3.34
	41	7.20	3.32	7.71	3.37	8.04	3.42	8.32	3.48	8.72	3.53	8.92	3.57
7+7+9+9	21	8.39	2.22	8.98	2.26	9.36	2.29	9.69	2.33	10.16	2.37	10.39	2.40
	24	8.27	2.44	8.85	2.48	9.23	2.52	9.55	2.56	10.01	2.60	10.24	2.63
	29	7.97	2.80	8.53	2.85	8.89	2.89	9.20	2.94	9.65	2.98	9.87	3.02
	35	7.61	3.10	8.15	3.15	8.49	3.19	8.79	3.25	9.22	3.30	9.43	3.34
	41	7.20	3.32	7.71	3.37	8.04	3.42	8.32	3.48	8.72	3.53	8.92	3.57
46	6.73	3.51	7.21	3.57	7.51	3.61	7.77	3.68	8.15	3.73	8.34	3.78	

Notes:

1. Capacities are based on the following conditions.
 Corresponding refrigerant piping length : 7.5m
 Level difference : 0m

2. TC : Total Capacity (kW)
 PI : Power Input (kW)



10. Capacity Table

10.5 A2UH146FA0

[Cooling Capacity]

Combination Capacity Index (kBtu/h)	Outdoor Air Temp.: °CDB	Indoor Air Temp.: °CWB											
		14		16		18		19		22		24	
		TC kW	PI kW	TC kW	PI kW	TC kW	PI kW	TC kW	PI kW	TC kW	PI kW	TC kW	PI kW
7	21	2.63	0.92	2.81	0.94	2.93	0.95	3.04	0.97	3.18	0.98	3.26	1.00
	24	2.59	1.01	2.77	1.03	2.89	1.04	2.99	1.06	3.14	1.08	3.21	1.09
	29	2.50	1.16	2.67	1.18	2.79	1.20	2.88	1.22	3.02	1.24	3.09	1.25
	35	2.38	1.29	2.55	1.31	2.66	1.33	2.75	1.35	2.89	1.37	2.95	1.39
	41	2.26	1.38	2.42	1.40	2.52	1.42	2.61	1.45	2.73	1.47	2.80	1.48
	46	2.11	1.46	2.26	1.48	2.35	1.50	2.44	1.53	2.55	1.55	2.61	1.57
7+7	21	4.03	0.99	4.31	1.01	4.49	1.02	4.65	1.04	4.87	1.06	4.99	1.07
	24	3.97	1.09	4.25	1.11	4.43	1.12	4.58	1.14	4.81	1.16	4.92	1.17
	29	3.82	1.25	4.10	1.27	4.27	1.29	4.42	1.31	4.63	1.33	4.74	1.35
	35	3.65	1.38	3.91	1.41	4.08	1.42	4.22	1.45	4.42	1.47	4.53	1.49
	41	3.46	1.48	3.70	1.50	3.86	1.52	3.99	1.55	4.19	1.57	4.28	1.59
	46	3.23	1.56	3.46	1.59	3.60	1.61	3.73	1.64	3.91	1.66	4.00	1.68

Notes:

1. Capacities are based on the following conditions.
 Corresponding refrigerant piping length : 7.5m
 Level difference : 0m

2. TC : Total Capacity (kW)
 PI : Power Input (kW)

[Heating Capacity]

Combination Capacity Index (kBtu/h)	Indoor Air Temp.: °CDB	Outdoor Air Temp.: °CWB											
		-10		-5		0		6		10		15	
		TC kW	PI kW	TC kW	PI kW	TC kW	PI kW	TC kW	PI kW	TC kW	PI kW	TC kW	PI kW
7	16	1.98	1.09	2.33	1.20	2.70	1.30	3.14	1.41	3.39	1.48	3.75	1.59
	18	1.92	1.13	2.26	1.24	2.61	1.35	3.04	1.45	3.29	1.53	3.63	1.64
	20	1.86	1.17	2.19	1.28	2.53	1.39	2.93	1.50	3.19	1.58	3.52	1.69
	22	1.79	1.21	2.11	1.32	2.44	1.43	2.84	1.55	3.07	1.63	3.39	1.75
	24	1.73	1.24	2.04	1.36	2.36	1.48	2.74	1.60	2.97	1.68	3.28	1.80
7+7	16	2.89	0.95	3.40	1.04	3.94	1.13	4.58	1.22	4.96	1.28	5.47	1.37
	18	2.80	0.98	3.30	1.07	3.81	1.17	4.43	1.26	4.80	1.33	5.30	1.42
	20	2.71	1.01	3.20	1.11	3.70	1.20	4.28	1.30	4.66	1.37	5.14	1.47
	22	2.62	1.04	3.08	1.14	3.57	1.24	4.15	1.34	4.49	1.41	4.95	1.51
	24	2.53	1.08	2.98	1.18	3.44	1.28	4.00	1.38	4.33	1.46	4.78	1.56

Notes:

1. Capacities are based on the following conditions.
 Corresponding refrigerant piping length : 7.5m
 Level difference : 0m

2. TC : Total Capacity (kW)
 PI : Power Input (kW)

10. Capacity Table

10.6 A2UH186FA0

[Cooling Capacity]

Combination Capacity Index (kBtu/h)	Outdoor Air Temp.: °CDB	Indoor Air Temp.: °CWB											
		14		16		18		19		22		24	
		TC kW	PI kW	TC kW	PI kW	TC kW	PI kW	TC kW	PI kW	TC kW	PI kW	TC kW	PI kW
7	21	1.96	0.53	2.10	0.54	2.18	0.55	2.26	0.56	2.37	0.57	2.42	0.58
	24	1.93	0.59	2.07	0.60	2.15	0.60	2.23	0.62	2.34	0.62	2.39	0.63
	29	1.86	0.67	1.99	0.68	2.07	0.69	2.15	0.71	2.25	0.72	2.30	0.72
	35	1.78	0.74	1.90	0.76	1.98	0.77	2.05	0.78	2.15	0.79	2.20	0.80
	41	1.68	0.80	1.80	0.81	1.88	0.82	1.94	0.83	2.03	0.85	2.08	0.86
	46	1.57	0.84	1.68	0.86	1.75	0.87	1.81	0.88	1.90	0.90	1.95	0.91
9	21	2.66	0.75	2.84	0.77	2.96	0.78	3.07	0.79	3.22	0.80	3.29	0.81
	24	2.62	0.83	2.80	0.84	2.92	0.85	3.02	0.87	3.17	0.88	3.24	0.89
	29	2.52	0.95	2.70	0.96	2.82	0.98	2.91	1.00	3.06	1.01	3.13	1.02
	35	2.41	1.05	2.58	1.07	2.69	1.08	2.78	1.10	2.92	1.12	2.99	1.13
	41	2.28	1.12	2.44	1.14	2.54	1.16	2.63	1.18	2.76	1.19	2.83	1.21
	46	2.13	1.19	2.28	1.21	2.38	1.22	2.46	1.24	2.58	1.26	2.64	1.28
12	21	3.07	0.75	3.29	0.77	3.43	0.78	3.55	0.79	3.72	0.80	3.81	0.81
	24	3.03	0.83	3.25	0.84	3.38	0.85	3.50	0.87	3.67	0.88	3.76	0.89
	29	2.92	0.95	3.13	0.96	3.26	0.98	3.38	1.00	3.54	1.01	3.62	1.02
	35	2.79	1.05	2.99	1.07	3.11	1.08	3.22	1.10	3.38	1.12	3.46	1.13
	41	2.64	1.12	2.83	1.14	2.95	1.16	3.05	1.18	3.20	1.19	3.27	1.21
	46	2.47	1.19	2.64	1.21	2.75	1.22	2.85	1.24	2.99	1.26	3.06	1.28
7+7	21	3.91	1.30	4.19	1.32	4.37	1.34	4.52	1.36	4.74	1.38	4.85	1.40
	24	3.86	1.43	4.13	1.45	4.31	1.47	4.46	1.50	4.67	1.52	4.78	1.54
	29	3.72	1.64	3.98	1.67	4.15	1.69	4.30	1.72	4.50	1.74	4.61	1.76
	35	3.55	1.81	3.80	1.84	3.96	1.87	4.10	1.90	4.30	1.93	4.40	1.95
	41	3.36	1.94	3.60	1.97	3.75	2.00	3.88	2.03	4.07	2.06	4.16	2.09
	46	3.14	2.05	3.36	2.08	3.50	2.11	3.63	2.15	3.80	2.18	3.89	2.21
7+9	21	4.47	1.30	4.79	1.32	4.99	1.34	5.17	1.36	5.42	1.38	5.54	1.40
	24	4.41	1.43	4.72	1.45	4.92	1.47	5.09	1.50	5.34	1.52	5.46	1.54
	29	4.25	1.64	4.55	1.67	4.74	1.69	4.91	1.72	5.15	1.74	5.27	1.76
	35	4.06	1.81	4.35	1.84	4.53	1.87	4.69	1.90	4.91	1.93	5.03	1.95
	41	3.84	1.94	4.11	1.97	4.29	2.00	4.44	2.03	4.65	2.06	4.76	2.09
	46	3.59	2.05	3.84	2.08	4.01	2.11	4.15	2.15	4.35	2.18	4.45	2.21
9+9	21	5.03	1.30	5.39	1.32	5.62	1.34	5.81	1.36	6.09	1.38	6.24	1.40
	24	4.96	1.43	5.31	1.45	5.54	1.47	5.73	1.50	6.01	1.52	6.15	1.54
	29	4.78	1.64	5.12	1.67	5.34	1.69	5.52	1.72	5.79	1.74	5.92	1.76
	35	4.57	1.81	4.89	1.84	5.10	1.87	5.28	1.90	5.53	1.93	5.66	1.95
	41	4.32	1.94	4.63	1.97	4.82	2.00	4.99	2.03	5.23	2.06	5.35	2.09
	46	4.04	2.05	4.32	2.08	4.51	2.11	4.66	2.15	4.89	2.18	5.00	2.21
7+12	21	5.03	1.30	5.39	1.32	5.62	1.34	5.81	1.36	6.09	1.38	6.24	1.40
	24	4.96	1.43	5.31	1.45	5.54	1.47	5.73	1.50	6.01	1.52	6.15	1.54
	29	4.78	1.64	5.12	1.67	5.34	1.69	5.52	1.72	5.79	1.74	5.92	1.76
	35	4.57	1.81	4.89	1.84	5.10	1.87	5.28	1.90	5.53	1.93	5.66	1.95
	41	4.32	1.94	4.63	1.97	4.82	2.00	4.99	2.03	5.23	2.06	5.35	2.09
	46	4.04	2.05	4.32	2.08	4.51	2.11	4.66	2.15	4.89	2.18	5.00	2.21

Notes:

1. Capacities are based on the following conditions.
 Corresponding refrigerant piping length : 7.5m
 Level difference : 0m

2. TC : Total Capacity (kW)
 PI : Power Input (kW)



10. Capacity Table

Heat Pump

[Heating Capacity]

Combination Capacity Index (kBtu/h)	Indoor Air Temp.: °CDB	Outdoor Air Temp.: °CWB											
		-10		-5		0		6		10		15	
		TC kW	PI kW	TC kW	PI kW	TC kW	PI kW	TC kW	PI kW	TC kW	PI kW	TC kW	PI kW
7	16	1.78	0.95	2.10	1.04	2.43	1.13	2.82	1.22	3.06	1.28	3.37	1.37
	18	1.72	0.98	2.03	1.07	2.35	1.17	2.73	1.26	2.96	1.33	3.27	1.42
	20	1.67	1.01	1.97	1.11	2.28	1.20	2.64	1.30	2.87	1.37	3.17	1.47
	22	1.61	1.04	1.90	1.14	2.20	1.24	2.56	1.34	2.77	1.41	3.05	1.51
	24	1.56	1.08	1.83	1.18	2.12	1.28	2.47	1.38	2.67	1.46	2.95	1.56
9	16	2.08	0.91	2.45	1.00	2.83	1.08	3.29	1.17	3.56	1.23	3.93	1.32
	18	2.01	0.94	2.37	1.03	2.74	1.12	3.19	1.21	3.45	1.28	3.81	1.37
	20	1.95	0.97	2.30	1.06	2.66	1.16	3.08	1.25	3.35	1.32	3.70	1.41
	22	1.88	1.00	2.22	1.10	2.56	1.20	2.98	1.29	3.23	1.36	3.56	1.46
	24	1.82	1.04	2.14	1.13	2.48	1.23	2.88	1.33	3.12	1.40	3.44	1.50
12	16	2.39	0.87	2.82	0.96	3.26	1.04	3.79	1.12	4.11	1.18	4.53	1.27
	18	2.32	0.90	2.73	0.99	3.16	1.08	3.67	1.16	3.98	1.22	4.39	1.31
	20	2.25	0.93	2.65	1.02	3.07	1.11	3.54	1.20	3.86	1.26	4.26	1.35
	22	2.17	0.96	2.55	1.05	2.96	1.15	3.44	1.24	3.72	1.30	4.11	1.40
	24	2.09	0.99	2.47	1.09	2.85	1.18	3.32	1.28	3.59	1.34	3.96	1.44
7+7	16	3.05	1.39	3.59	1.51	4.15	1.65	4.83	1.78	5.23	1.87	5.77	2.01
	18	2.95	1.43	3.48	1.57	4.02	1.71	4.68	1.84	5.06	1.94	5.59	2.08
	20	2.86	1.48	3.37	1.62	3.90	1.76	4.51	1.90	4.91	2.00	5.42	2.14
	22	2.76	1.53	3.25	1.67	3.76	1.82	4.37	1.96	4.73	2.07	5.23	2.21
	24	2.66	1.57	3.14	1.72	3.63	1.87	4.22	2.02	4.57	2.13	5.05	2.28
7+9	16	3.48	1.39	4.10	1.51	4.75	1.65	5.52	1.78	5.97	1.87	6.59	2.01
	18	3.37	1.43	3.97	1.57	4.60	1.71	5.34	1.84	5.79	1.94	6.39	2.08
	20	3.27	1.48	3.85	1.62	4.46	1.76	5.16	1.90	5.61	2.00	6.20	2.14
	22	3.15	1.53	3.72	1.67	4.30	1.82	5.00	1.96	5.41	2.07	5.97	2.21
	24	3.05	1.57	3.59	1.72	4.15	1.87	4.83	2.02	5.22	2.13	5.77	2.28
9+9	16	3.92	1.39	4.62	1.51	5.34	1.65	6.21	1.78	6.72	1.87	7.42	2.01
	18	3.79	1.43	4.47	1.57	5.17	1.71	6.01	1.84	6.51	1.94	7.18	2.08
	20	3.68	1.48	4.34	1.62	5.02	1.76	5.80	1.90	6.31	2.00	6.97	2.14
	22	3.55	1.53	4.18	1.67	4.84	1.82	5.62	1.96	6.09	2.07	6.72	2.21
	24	3.43	1.57	4.04	1.72	4.67	1.87	5.43	2.02	5.88	2.13	6.49	2.28
7+12	16	3.92	1.39	4.62	1.51	5.34	1.65	6.21	1.78	6.72	1.87	7.42	2.01
	18	3.79	1.43	4.47	1.57	5.17	1.71	6.01	1.84	6.51	1.94	7.18	2.08
	20	3.68	1.48	4.34	1.62	5.02	1.76	5.80	1.90	6.31	2.00	6.97	2.14
	22	3.55	1.53	4.18	1.67	4.84	1.82	5.62	1.96	6.09	2.07	6.72	2.21
	24	3.43	1.57	4.04	1.72	4.67	1.87	5.43	2.02	5.88	2.13	6.49	2.28

Notes:

1. Capacities are based on the following conditions.
 Corresponding refrigerant piping length : 7.5m
 Level difference : 0m

2. TC : Total Capacity (kW)
 PI : Power Input (kW)

10. Capacity Table

Heat Pump

10.7 A3UH216FA0

[Cooling Capacity]

Combination Capacity Index (kBtu/h)	Outdoor Air Temp.: °CDB	Indoor Air Temp.: °CWB											
		14		16		18		19		22		24	
		TC kW	PI kW	TC kW	PI kW	TC kW	PI kW	TC kW	PI kW	TC kW	PI kW	TC kW	PI kW
7	21	2.24	0.60	2.40	0.61	2.50	0.62	2.58	0.63	2.71	0.64	2.77	0.65
	24	2.20	0.66	2.36	0.67	2.46	0.68	2.55	0.69	2.67	0.70	2.73	0.71
	29	2.12	0.76	2.28	0.77	2.37	0.78	2.45	0.80	2.57	0.81	2.63	0.82
	35	2.03	0.84	2.17	0.85	2.26	0.86	2.34	0.88	2.46	0.89	2.51	0.90
	41	1.92	0.90	2.06	0.91	2.14	0.92	2.22	0.94	2.33	0.96	2.38	0.97
	46	1.79	0.95	1.92	0.97	2.00	0.98	2.07	1.00	2.17	1.01	2.22	1.02
9	21	2.66	0.62	2.84	0.63	2.96	0.63	3.07	0.65	3.22	0.66	3.29	0.66
	24	2.62	0.68	2.80	0.69	2.92	0.70	3.02	0.71	3.17	0.72	3.24	0.73
	29	2.52	0.78	2.70	0.79	2.82	0.80	2.91	0.81	3.06	0.83	3.13	0.84
	35	2.41	0.86	2.58	0.87	2.69	0.88	2.78	0.90	2.92	0.91	2.99	0.92
	41	2.28	0.92	2.44	0.93	2.54	0.95	2.63	0.96	2.76	0.98	2.83	0.99
	46	2.13	0.97	2.28	0.99	2.38	1.00	2.46	1.02	2.58	1.03	2.64	1.05
12(ART COOL)	21	3.07	0.79	3.29	0.80	3.43	0.81	3.55	0.83	3.72	0.84	3.81	0.85
	24	3.03	0.86	3.25	0.88	3.38	0.89	3.50	0.91	3.67	0.92	3.76	0.93
	29	2.92	0.99	3.13	1.01	3.26	1.02	3.38	1.04	3.54	1.06	3.62	1.07
	35	2.79	1.10	2.99	1.11	3.11	1.13	3.22	1.15	3.38	1.17	3.46	1.18
	41	2.64	1.17	2.83	1.19	2.95	1.21	3.05	1.23	3.20	1.25	3.27	1.26
	46	2.47	1.24	2.64	1.26	2.75	1.28	2.85	1.30	2.99	1.32	3.06	1.34
12	21	3.35	0.79	3.59	0.80	3.74	0.81	3.88	0.83	4.06	0.84	4.16	0.85
	24	3.31	0.86	3.54	0.88	3.69	0.89	3.82	0.91	4.00	0.92	4.10	0.93
	29	3.19	0.99	3.41	1.01	3.56	1.02	3.68	1.04	3.86	1.06	3.95	1.07
	35	3.04	1.10	3.26	1.11	3.40	1.13	3.52	1.15	3.69	1.17	3.77	1.18
	41	2.88	1.17	3.08	1.19	3.21	1.21	3.33	1.23	3.49	1.25	3.57	1.26
	46	2.69	1.24	2.88	1.26	3.00	1.28	3.11	1.30	3.26	1.32	3.34	1.34
7+7	21	4.70	1.44	5.03	1.46	5.24	1.48	5.43	1.51	5.69	1.53	5.82	1.55
	24	4.63	1.58	4.96	1.61	5.17	1.63	5.35	1.66	5.61	1.68	5.74	1.70
	29	4.46	1.81	4.78	1.84	4.98	1.86	5.15	1.90	5.40	1.93	5.53	1.95
	35	4.26	2.00	4.56	2.04	4.76	2.06	4.92	2.10	5.16	2.13	5.28	2.16
	41	4.03	2.14	4.32	2.18	4.50	2.21	4.66	2.25	4.88	2.28	5.00	2.31
	46	3.77	2.26	4.04	2.30	4.21	2.33	4.35	2.38	4.56	2.41	4.67	2.44
7+9	21	5.03	1.44	5.39	1.46	5.62	1.48	5.81	1.51	6.09	1.53	6.24	1.55
	24	4.96	1.58	5.31	1.61	5.54	1.63	5.73	1.66	6.01	1.68	6.15	1.70
	29	4.78	1.81	5.12	1.84	5.34	1.86	5.52	1.90	5.79	1.93	5.92	1.95
	35	4.57	2.00	4.89	2.04	5.10	2.06	5.28	2.10	5.53	2.13	5.66	2.16
	41	4.32	2.14	4.63	2.18	4.82	2.21	4.99	2.25	5.23	2.28	5.35	2.31
	46	4.04	2.26	4.32	2.30	4.51	2.33	4.66	2.38	4.89	2.41	5.00	2.44
9+9	21	5.31	1.44	5.69	1.46	5.93	1.48	6.14	1.51	6.43	1.53	6.58	1.55
	24	5.24	1.58	5.61	1.61	5.84	1.63	6.05	1.66	6.34	1.68	6.49	1.70
	29	5.05	1.81	5.40	1.84	5.63	1.86	5.83	1.90	6.11	1.93	6.25	1.95
	35	4.82	2.00	5.16	2.04	5.38	2.06	5.57	2.10	5.84	2.13	5.97	2.16
	41	4.56	2.14	4.88	2.18	5.09	2.21	5.27	2.25	5.52	2.28	5.65	2.31
	46	4.26	2.26	4.56	2.30	4.76	2.33	4.92	2.38	5.16	2.41	5.28	2.44
7+12(ART COOL)	21	5.31	1.44	5.69	1.46	5.93	1.48	6.14	1.51	6.43	1.53	6.58	1.55
	24	5.24	1.58	5.61	1.61	5.84	1.63	6.05	1.66	6.34	1.68	6.49	1.70
	29	5.05	1.81	5.40	1.84	5.63	1.86	5.83	1.90	6.11	1.93	6.25	1.95
	35	4.82	2.00	5.16	2.04	5.38	2.06	5.57	2.10	5.84	2.13	5.97	2.16
	41	4.56	2.14	4.88	2.18	5.09	2.21	5.27	2.25	5.52	2.28	5.65	2.31
	46	4.26	2.26	4.56	2.30	4.76	2.33	4.92	2.38	5.16	2.41	5.28	2.44
7+12	21	5.59	1.44	5.99	1.46	6.24	1.48	6.46	1.51	6.77	1.53	6.93	1.55
	24	5.51	1.58	5.90	1.61	6.15	1.63	6.37	1.66	6.67	1.68	6.83	1.70
	29	5.31	1.81	5.69	1.84	5.93	1.86	6.14	1.90	6.43	1.93	6.58	1.95
	35	5.07	2.00	5.43	2.04	5.66	2.06	5.86	2.10	6.14	2.13	6.29	2.16
	41	4.80	2.14	5.14	2.18	5.36	2.21	5.55	2.25	5.81	2.28	5.95	2.31
	46	4.49	2.26	4.80	2.30	5.01	2.33	5.18	2.38	5.43	2.41	5.56	2.44
9+12	21	5.87	1.44	6.29	1.46	6.55	1.48	6.78	1.51	7.11	1.53	7.27	1.55
	24	5.79	1.58	6.20	1.61	6.46	1.63	6.69	1.66	7.01	1.68	7.17	1.70
	29	5.58	1.81	5.97	1.84	6.22	1.86	6.44	1.90	6.75	1.93	6.91	1.95
	35	5.33	2.00	5.71	2.04	5.95	2.06	6.15	2.10	6.45	2.13	6.60	2.16
	41	5.04	2.14	5.40	2.18	5.63	2.21	5.82	2.25	6.10	2.28	6.25	2.31
	46	4.71	2.26	5.04	2.30	5.26	2.33	5.44	2.38	5.70	2.41	5.84	2.44
7+7+7	21	5.87	1.44	6.29	1.46	6.55	1.48	6.78	1.51	7.11	1.53	7.27	1.55
	24	5.79	1.58	6.20	1.61	6.46	1.63	6.69	1.66	7.01	1.68	7.17	1.70
	29	5.58	1.81	5.97	1.84	6.22	1.86	6.44	1.90	6.75	1.93	6.91	1.95
	35	5.33	2.00	5.71	2.04	5.95	2.06	6.15	2.10	6.45	2.13	6.60	2.16
	41	5.04	2.14	5.40	2.18	5.63	2.21	5.82	2.25	6.10	2.28	6.25	2.31
	46	4.71	2.26	5.04	2.30	5.26	2.33	5.44	2.38	5.70	2.41	5.84	2.44
7+7+9	21	5.87	1.44	6.29	1.46	6.55	1.48	6.78	1.51	7.11	1.53	7.27	1.55
	24	5.79	1.58	6.20	1.61	6.46	1.63	6.69	1.66	7.01	1.68	7.17	1.70
	29	5.58	1.81	5.97	1.84	6.22	1.86	6.44	1.90	6.75	1.93	6.91	1.95
	35	5.33	2.00	5.71	2.04	5.95	2.06	6.15	2.10	6.45	2.13	6.60	2.16
	41	5.04	2.14	5.40	2.18	5.63	2.21	5.82	2.25	6.10	2.28	6.25	2.31
	46	4.71	2.26	5.04	2.30	5.26	2.33	5.44	2.38	5.70	2.41	5.84	2.44

Notes:

1. Capacities are based on the following conditions.
 Corresponding refrigerant piping length : 7.5m
 Level difference : 0m

2. TC : Total Capacity (kW)
 PI : Power Input (kW)



10. Capacity Table

Heat Pump

[Heating Capacity]

Combination Capacity Index (kBtu/h)	Indoor Air Temp.: °CDB	Outdoor Air Temp.: °CWB											
		-10		-5		0		6		10		15	
		TC kW	PI kW	TC kW	PI kW	TC kW	PI kW	TC kW	PI kW	TC kW	PI kW	TC kW	PI kW
7	16	1.78	0.98	2.10	1.08	2.43	1.17	2.82	1.27	3.06	1.33	3.37	1.43
	18	1.72	1.02	2.03	1.11	2.35	1.21	2.73	1.31	2.96	1.38	3.27	1.48
	20	1.67	1.05	1.97	1.15	2.28	1.25	2.64	1.35	2.87	1.42	3.17	1.52
	22	1.61	1.08	1.90	1.19	2.20	1.29	2.56	1.39	2.77	1.47	3.05	1.57
	24	1.56	1.12	1.83	1.22	2.12	1.33	2.47	1.44	2.67	1.51	2.95	1.62
9	16	2.07	0.98	2.44	1.08	2.82	1.17	3.28	1.27	3.55	1.33	3.92	1.43
	18	2.00	1.02	2.36	1.11	2.73	1.21	3.17	1.31	3.44	1.38	3.79	1.48
	20	1.94	1.05	2.29	1.15	2.65	1.25	3.06	1.35	3.33	1.42	3.68	1.52
	22	1.87	1.08	2.21	1.19	2.55	1.29	2.97	1.39	3.21	1.47	3.55	1.57
	24	1.81	1.12	2.13	1.22	2.46	1.33	2.87	1.44	3.10	1.51	3.42	1.62
12(ART COOL)	16	2.39	1.02	2.82	1.12	3.26	1.22	3.79	1.31	4.11	1.38	4.53	1.48
	18	2.32	1.06	2.73	1.15	3.16	1.26	3.67	1.36	3.98	1.43	4.39	1.53
	20	2.25	1.09	2.65	1.19	3.07	1.30	3.54	1.40	3.86	1.48	4.26	1.58
	22	2.17	1.12	2.55	1.23	2.96	1.34	3.44	1.45	3.72	1.52	4.11	1.63
	24	2.09	1.16	2.47	1.27	2.85	1.38	3.32	1.49	3.59	1.57	3.96	1.68
12	16	2.61	1.02	3.08	1.12	3.56	1.22	4.14	1.31	4.48	1.38	4.95	1.48
	18	2.53	1.06	2.98	1.15	3.45	1.26	4.01	1.36	4.34	1.43	4.79	1.53
	20	2.45	1.09	2.89	1.19	3.34	1.30	3.87	1.40	4.21	1.48	4.65	1.58
	22	2.37	1.12	2.79	1.23	3.22	1.34	3.75	1.45	4.06	1.52	4.48	1.63
	24	2.28	1.16	2.69	1.27	3.11	1.38	3.62	1.49	3.92	1.57	4.33	1.68
7+7	16	3.64	1.60	4.29	1.75	4.96	1.91	5.77	2.06	6.25	2.17	6.89	2.32
	18	3.53	1.66	4.15	1.81	4.81	1.97	5.59	2.13	6.05	2.24	6.68	2.40
	20	3.42	1.71	4.03	1.87	4.66	2.04	5.39	2.20	5.87	2.32	6.48	2.48
	22	3.30	1.77	3.88	1.93	4.49	2.10	5.23	2.27	5.66	2.39	6.24	2.56
	24	3.18	1.82	3.75	1.99	4.34	2.17	5.05	2.34	5.46	2.47	6.03	2.64
7+9	16	3.92	1.60	4.62	1.75	5.34	1.91	6.21	2.06	6.72	2.17	7.42	2.32
	18	3.79	1.66	4.47	1.81	5.17	1.97	6.01	2.13	6.51	2.24	7.18	2.40
	20	3.68	1.71	4.34	1.87	5.02	2.04	5.80	2.20	6.31	2.32	6.97	2.48
	22	3.55	1.77	4.18	1.93	4.84	2.10	5.62	2.27	6.09	2.39	6.72	2.56
	24	3.43	1.82	4.04	1.99	4.67	2.17	5.43	2.34	5.88	2.47	6.49	2.64
9+9	16	3.96	1.60	4.66	1.75	5.39	1.91	6.27	2.06	6.79	2.17	7.49	2.32
	18	3.83	1.66	4.51	1.81	5.22	1.97	6.07	2.13	6.57	2.24	7.26	2.40
	20	3.72	1.71	4.38	1.87	5.07	2.04	5.86	2.20	6.38	2.32	7.04	2.48
	22	3.58	1.77	4.22	1.93	4.88	2.10	5.68	2.27	6.15	2.39	6.79	2.56
	24	3.46	1.82	4.08	1.99	4.72	2.17	5.49	2.34	5.94	2.47	6.55	2.64
7+12(ART COOL)	16	4.14	1.60	4.87	1.75	5.64	1.91	6.55	2.06	7.10	2.17	7.83	2.32
	18	4.00	1.66	4.72	1.81	5.46	1.97	6.35	2.13	6.87	2.24	7.58	2.40
	20	3.89	1.71	4.58	1.87	5.30	2.04	6.12	2.20	6.67	2.32	7.36	2.48
	22	3.75	1.77	4.41	1.93	5.10	2.10	5.94	2.27	6.43	2.39	7.09	2.56
	24	3.62	1.82	4.26	1.99	4.93	2.17	5.73	2.34	6.20	2.47	6.85	2.64
7+12	16	4.16	1.60	4.90	1.75	5.66	1.91	6.59	2.06	7.13	2.17	7.87	2.32
	18	4.02	1.66	4.74	1.81	5.48	1.97	6.38	2.13	6.90	2.24	7.62	2.40
	20	3.90	1.71	4.60	1.87	5.32	2.04	6.15	2.20	6.70	2.32	7.39	2.48
	22	3.76	1.77	4.43	1.93	5.13	2.10	5.96	2.27	6.46	2.39	7.13	2.56
	24	3.63	1.82	4.28	1.99	4.95	2.17	5.76	2.34	6.23	2.47	6.88	2.64
9+12	16	4.16	1.39	4.90	1.51	5.66	1.65	6.59	1.78	7.13	1.87	7.87	2.01
	18	4.02	1.43	4.74	1.57	5.48	1.71	6.38	1.84	6.90	1.94	7.62	2.08
	20	3.90	1.48	4.60	1.62	5.32	1.76	6.15	1.90	6.70	2.00	7.39	2.14
	22	3.76	1.53	4.43	1.67	5.13	1.82	5.96	1.96	6.46	2.07	7.13	2.21
	24	3.63	1.57	4.28	1.72	4.95	1.87	5.76	2.02	6.23	2.13	6.88	2.28
7+7+7	16	4.16	1.39	4.90	1.51	5.66	1.65	6.59	1.78	7.13	1.87	7.87	2.01
	18	4.02	1.43	4.74	1.57	5.48	1.71	6.38	1.84	6.90	1.94	7.62	2.08
	20	3.90	1.48	4.60	1.62	5.32	1.76	6.15	1.90	6.70	2.00	7.39	2.14
	22	3.76	1.53	4.43	1.67	5.13	1.82	5.96	1.96	6.46	2.07	7.13	2.21
	24	3.63	1.57	4.28	1.72	4.95	1.87	5.76	2.02	6.23	2.13	6.88	2.28
7+7+9	16	4.16	1.39	4.90	1.51	5.66	1.65	6.59	1.78	7.13	1.87	7.87	2.01
	18	4.02	1.43	4.74	1.57	5.48	1.71	6.38	1.84	6.90	1.94	7.62	2.08
	20	3.90	1.48	4.60	1.62	5.32	1.76	6.15	1.90	6.70	2.00	7.39	2.14
	22	3.76	1.53	4.43	1.67	5.13	1.82	5.96	1.96	6.46	2.07	7.13	2.21
	24	3.63	1.57	4.28	1.72	4.95	1.87	5.76	2.02	6.23	2.13	6.88	2.28

Notes:

1. Capacities are based on the following conditions.
 Corresponding refrigerant piping length : 7.5m
 Level difference : 0m

2. TC : Total Capacity (kW)
 PI : Power Input (kW)

10. Capacity Table

Heat Pump

10.8 A4UH306FA0

[Cooling Capacity]

Combination Capacity Index (kBtu/h)	Outdoor Air Temp.: °CDB	Indoor Air Temp.: °CWB											
		14		16		18		19		22		24	
		TC kW	PI kW	TC kW	PI kW	TC kW	PI kW	TC kW	PI kW	TC kW	PI kW	TC kW	PI kW
7	21	2.52	0.82	2.69	0.84	2.81	0.85	2.91	0.86	3.05	0.87	3.12	0.88
	24	2.48	0.90	2.66	0.92	2.77	0.93	2.87	0.95	3.00	0.96	3.07	0.97
	29	2.39	1.03	2.56	1.05	2.67	1.07	2.76	1.09	2.89	1.10	2.96	1.11
	35	2.28	1.14	2.45	1.16	2.55	1.18	2.64	1.20	2.76	1.22	2.83	1.23
	41	2.16	1.22	2.31	1.25	2.41	1.26	2.50	1.28	2.62	1.30	2.68	1.32
9	21	2.80	0.82	2.99	0.84	3.12	0.85	3.23	0.86	3.39	0.87	3.46	0.88
	24	2.76	0.90	2.95	0.92	3.08	0.93	3.18	0.95	3.34	0.96	3.41	0.97
	29	2.66	1.03	2.84	1.05	2.96	1.07	3.07	1.09	3.22	1.10	3.29	1.11
	35	2.54	1.14	2.72	1.16	2.83	1.18	2.93	1.20	3.07	1.22	3.14	1.23
	41	2.40	1.22	2.57	1.25	2.68	1.26	2.77	1.28	2.91	1.30	2.97	1.32
12	21	2.24	1.29	2.40	1.32	2.50	1.33	2.59	1.36	2.72	1.38	2.78	1.39
	24	3.35	0.82	3.59	0.84	3.74	0.85	3.88	0.86	4.06	0.87	4.16	0.88
	29	3.31	0.90	3.54	0.92	3.69	0.93	3.82	0.95	4.00	0.96	4.10	0.97
	35	3.19	1.03	3.41	1.05	3.56	1.07	3.68	1.09	3.86	1.10	3.95	1.11
	41	3.04	1.14	3.26	1.16	3.40	1.18	3.52	1.20	3.69	1.22	3.77	1.23
18	21	2.88	1.22	3.08	1.25	3.21	1.26	3.33	1.28	3.49	1.30	3.57	1.32
	24	2.69	1.29	2.88	1.32	3.00	1.33	3.11	1.36	3.26	1.38	3.34	1.39
	29	5.03	1.33	5.39	1.36	5.62	1.37	5.81	1.40	6.09	1.42	6.24	1.44
	35	4.96	1.47	5.31	1.49	5.54	1.51	5.73	1.54	6.01	1.56	6.15	1.58
	41	4.78	1.68	5.12	1.71	5.34	1.73	5.52	1.76	5.79	1.79	5.92	1.81
24	21	4.57	1.86	4.89	1.89	5.10	1.91	5.28	1.95	5.53	1.98	5.66	2.00
	24	4.32	1.99	4.63	2.02	4.82	2.05	4.99	2.09	5.23	2.12	5.35	2.14
	29	6.71	2.22	7.19	2.26	7.49	2.29	7.75	2.33	8.12	2.37	8.31	2.40
	35	6.61	2.44	7.08	2.48	7.38	2.52	7.64	2.56	8.01	2.60	8.20	2.63
	41	6.37	2.80	6.83	2.85	7.11	2.89	7.36	2.94	7.72	2.98	7.90	3.02
7+7	21	6.09	3.10	6.52	3.15	6.79	3.19	7.03	3.25	7.37	3.30	7.54	3.34
	24	5.76	3.32	6.17	3.37	6.43	3.42	6.65	3.48	6.98	3.53	7.14	3.57
	29	5.38	3.51	5.77	3.57	6.01	3.61	6.22	3.68	6.52	3.73	6.67	3.78
	35	4.47	1.33	4.79	1.36	4.99	1.37	5.17	1.40	5.42	1.42	5.54	1.44
	41	4.41	1.47	4.72	1.49	4.92	1.51	5.09	1.54	5.34	1.56	5.46	1.58
7+9	21	4.25	1.68	4.55	1.71	4.74	1.73	4.91	1.76	5.15	1.79	5.27	1.81
	24	4.06	1.86	4.35	1.89	4.53	1.91	4.69	1.95	4.91	1.98	5.03	2.00
	29	3.84	1.99	4.11	2.02	4.29	2.05	4.44	2.09	4.65	2.12	4.76	2.14
	35	3.59	2.10	3.84	2.14	4.01	2.17	4.15	2.21	4.35	2.24	4.45	2.27
	41	4.75	1.33	5.09	1.36	5.30	1.37	5.49	1.40	5.75	1.42	5.89	1.44
7+12	21	4.68	1.47	5.02	1.49	5.23	1.51	5.41	1.54	5.67	1.56	5.81	1.58
	24	4.51	1.68	4.84	1.71	5.04	1.73	5.22	1.76	5.47	1.79	5.59	1.81
	29	4.31	1.86	4.62	1.89	4.81	1.91	4.98	1.95	5.22	1.98	5.34	2.00
	35	4.08	1.99	4.37	2.02	4.55	2.05	4.71	2.09	4.94	2.12	5.06	2.14
	41	3.81	2.10	4.08	2.14	4.26	2.17	4.41	2.21	4.62	2.24	4.73	2.27
7+18	21	5.31	1.33	5.69	1.36	5.93	1.37	6.14	1.40	6.43	1.42	6.58	1.44
	24	5.24	1.47	5.61	1.49	5.84	1.51	6.05	1.54	6.34	1.56	6.49	1.58
	29	5.05	1.68	5.40	1.71	5.63	1.73	5.83	1.76	6.11	1.79	6.25	1.81
	35	4.82	1.86	5.16	1.89	5.38	1.91	5.57	1.95	5.84	1.98	5.97	2.00
	41	4.56	1.99	4.88	2.02	5.09	2.05	5.27	2.09	5.52	2.12	5.65	2.14
7+24	21	4.26	2.10	4.56	2.14	4.76	2.17	4.92	2.21	5.16	2.24	5.28	2.27
	24	5.03	2.22	5.39	2.26	5.62	2.29	5.81	2.33	6.09	2.37	6.24	2.40
	29	4.96	2.44	5.31	2.48	5.54	2.52	5.73	2.56	6.01	2.60	6.15	2.63
	35	4.78	2.80	5.12	2.85	5.34	2.89	5.52	2.94	5.79	2.98	5.92	3.02
	41	4.57	3.10	4.89	3.15	5.10	3.19	5.28	3.25	5.53	3.30	5.66	3.34
9+9	21	4.32	3.32	4.63	3.37	4.82	3.42	4.99	3.48	5.23	3.53	5.35	3.57
	24	4.04	3.51	4.32	3.57	4.51	3.61	4.66	3.68	4.89	3.73	5.00	3.78
	29	8.39	2.22	8.98	2.26	9.36	2.29	9.69	2.33	10.16	2.37	10.39	2.40
	35	8.27	2.44	8.85	2.48	9.23	2.52	9.55	2.56	10.01	2.60	10.24	2.63
	41	7.97	2.80	8.53	2.85	8.89	2.89	9.20	2.94	9.65	2.98	9.87	3.02
9+12	21	7.61	3.10	8.15	3.15	8.49	3.19	8.79	3.25	9.22	3.30	9.43	3.34
	24	7.20	3.32	7.71	3.37	8.04	3.42	8.32	3.48	8.72	3.53	8.92	3.57
	29	6.73	3.51	7.21	3.57	7.51	3.61	7.77	3.68	8.15	3.73	8.34	3.78
	35	5.03	1.33	5.39	1.36	5.62	1.37	5.81	1.40	6.09	1.42	6.24	1.44
	41	4.96	1.47	5.31	1.49	5.54	1.51	5.73	1.54	6.01	1.56	6.15	1.58



10. Capacity Table

Heat Pump

Combination Capacity Index (kBtu/h)	Outdoor Air Temp.: °CDB	Indoor Air Temp.: °CWB											
		14		16		18		19		22		24	
		TC	PI	TC	PI	TC	PI	TC	PI	TC	PI	TC	PI
		kW	kW	kW	kW	kW	kW	kW	kW	kW	kW	kW	kW
9+18	21	7.83	2.22	8.38	2.26	8.74	2.29	9.04	2.33	9.48	2.37	9.70	2.40
	24	7.72	2.44	8.26	2.48	8.61	2.52	8.91	2.56	9.34	2.60	9.56	2.63
	29	7.44	2.80	7.96	2.85	8.30	2.89	8.59	2.94	9.00	2.98	9.21	3.02
	35	7.10	3.10	7.61	3.15	7.93	3.19	8.21	3.25	8.60	3.30	8.80	3.34
	41	6.72	3.32	7.20	3.37	7.50	3.42	7.76	3.48	8.14	3.53	8.33	3.57
9+24	46	6.28	3.51	6.73	3.57	7.01	3.61	7.26	3.68	7.60	3.73	7.78	3.78
	21	8.39	2.22	8.98	2.26	9.36	2.29	9.69	2.33	10.16	2.37	10.39	2.40
	24	8.27	2.44	8.85	2.48	9.23	2.52	9.55	2.56	10.01	2.60	10.24	2.63
	29	7.97	2.80	8.53	2.85	8.89	2.89	9.20	2.94	9.65	2.98	9.87	3.02
	35	7.61	3.10	8.15	3.15	8.49	3.19	8.79	3.25	9.22	3.30	9.43	3.34
12+12	41	7.20	3.32	7.71	3.37	8.04	3.42	8.32	3.48	8.72	3.53	8.92	3.57
	46	6.73	3.51	7.21	3.57	7.51	3.61	7.77	3.68	8.15	3.73	8.34	3.78
	21	7.27	2.22	7.78	2.26	8.11	2.29	8.40	2.33	8.80	2.37	9.01	2.40
	24	7.16	2.44	7.67	2.48	8.00	2.52	8.28	2.56	8.68	2.60	8.88	2.63
	29	6.90	2.80	7.40	2.85	7.71	2.89	7.98	2.94	8.36	2.98	8.56	3.02
12+18	35	6.59	3.10	7.06	3.15	7.36	3.19	7.62	3.25	7.99	3.30	8.17	3.34
	41	6.24	3.32	6.68	3.37	6.96	3.42	7.21	3.48	7.56	3.53	7.73	3.57
	46	5.83	3.51	6.25	3.57	6.51	3.61	6.74	3.68	7.06	3.73	7.23	3.78
	21	8.39	2.22	8.98	2.26	9.36	2.29	9.69	2.33	10.16	2.37	10.39	2.40
	24	8.27	2.44	8.85	2.48	9.23	2.52	9.55	2.56	10.01	2.60	10.24	2.63
12+24	29	7.97	2.80	8.53	2.85	8.89	2.89	9.20	2.94	9.65	2.98	9.87	3.02
	35	7.61	3.10	8.15	3.15	8.49	3.19	8.79	3.25	9.22	3.30	9.43	3.34
	41	7.20	3.32	7.71	3.37	8.04	3.42	8.32	3.48	8.72	3.53	8.92	3.57
	46	6.73	3.51	7.21	3.57	7.51	3.61	7.77	3.68	8.15	3.73	8.34	3.78
	21	7.55	2.22	8.08	2.26	8.42	2.29	8.72	2.33	9.14	2.37	9.35	2.40
7+7+7	24	7.44	2.44	7.97	2.48	8.30	2.52	8.60	2.56	9.01	2.60	9.22	2.63
	29	7.17	2.80	7.68	2.85	8.00	2.89	8.28	2.94	8.68	2.98	8.89	3.02
	35	6.85	3.10	7.34	3.15	7.64	3.19	7.91	3.25	8.29	3.30	8.49	3.34
	41	6.48	3.32	6.94	3.37	7.23	3.42	7.49	3.48	7.85	3.53	8.03	3.57
	46	6.06	3.51	6.49	3.57	6.76	3.61	7.00	3.68	7.33	3.73	7.50	3.78
7+7+9	21	8.11	2.22	8.68	2.26	9.05	2.29	9.37	2.33	9.82	2.37	10.05	2.40
	24	7.99	2.44	8.56	2.48	8.92	2.52	9.23	2.56	9.68	2.60	9.90	2.63
	29	7.70	2.80	8.25	2.85	8.60	2.89	8.90	2.94	9.33	2.98	9.54	3.02
	35	7.36	3.10	7.88	3.15	8.21	3.19	8.50	3.25	8.91	3.30	9.12	3.34
	41	6.96	3.32	7.45	3.37	7.77	3.42	8.04	3.48	8.43	3.53	8.63	3.57
7+7+12	46	6.50	3.51	6.97	3.57	7.26	3.61	7.51	3.68	7.88	3.73	8.06	3.78
	21	7.83	2.22	8.38	2.26	8.74	2.29	9.04	2.33	9.48	2.37	9.70	2.40
	24	7.72	2.44	8.26	2.48	8.61	2.52	8.91	2.56	9.34	2.60	9.56	2.63
	29	7.44	2.80	7.96	2.85	8.30	2.89	8.59	2.94	9.00	2.98	9.21	3.02
	35	7.10	3.10	7.61	3.15	7.93	3.19	8.21	3.25	8.60	3.30	8.80	3.34
7+7+18	41	6.72	3.32	7.20	3.37	7.50	3.42	7.76	3.48	8.14	3.53	8.33	3.57
	46	6.28	3.51	6.73	3.57	7.01	3.61	7.26	3.68	7.60	3.73	7.78	3.78
	21	8.39	2.22	8.98	2.26	9.36	2.29	9.69	2.33	10.16	2.37	10.39	2.40
	24	8.27	2.44	8.85	2.48	9.23	2.52	9.55	2.56	10.01	2.60	10.24	2.63
	29	7.97	2.80	8.53	2.85	8.89	2.89	9.20	2.94	9.65	2.98	9.87	3.02
7+9+9	35	7.61	3.10	8.15	3.15	8.49	3.19	8.79	3.25	9.22	3.30	9.43	3.34
	41	7.20	3.32	7.71	3.37	8.04	3.42	8.32	3.48	8.72	3.53	8.92	3.57
	46	6.73	3.51	7.21	3.57	7.51	3.61	7.77	3.68	8.15	3.73	8.34	3.78
	21	8.11	2.22	8.68	2.26	9.05	2.29	9.37	2.33	9.82	2.37	10.05	2.40
	24	7.99	2.44	8.56	2.48	8.92	2.52	9.23	2.56	9.68	2.60	9.90	2.63
7+9+12	29	7.70	2.80	8.25	2.85	8.60	2.89	8.90	2.94	9.33	2.98	9.54	3.02
	35	7.36	3.10	7.88	3.15	8.21	3.19	8.50	3.25	8.91	3.30	9.12	3.34
	41	6.96	3.32	7.45	3.37	7.77	3.42	8.04	3.48	8.43	3.53	8.63	3.57
	46	6.50	3.51	6.97	3.57	7.26	3.61	7.51	3.68	7.88	3.73	8.06	3.78
	21	8.39	2.22	8.98	2.26	9.36	2.29	9.69	2.33	10.16	2.37	10.39	2.40
7+12+12	24	8.27	2.44	8.85	2.48	9.23	2.52	9.55	2.56	10.01	2.60	10.24	2.63
	29	7.97	2.80	8.53	2.85	8.89	2.89	9.20	2.94	9.65	2.98	9.87	3.02
	35	7.61	3.10	8.15	3.15	8.49	3.19	8.79	3.25	9.22	3.30	9.43	3.34
	41	7.20	3.32	7.71	3.37	8.04	3.42	8.32	3.48	8.72	3.53	8.92	3.57
	46	6.73	3.51	7.21	3.57	7.51	3.61	7.77	3.68	8.15	3.73	8.34	3.78
9+9+9	21	8.39	2.22	8.98	2.26	9.36	2.29	9.69	2.33	10.16	2.37	10.39	2.40
	24	8.27	2.44	8.85	2.48	9.23	2.52	9.55	2.56	10.01	2.60	10.24	2.63
	29	7.97	2.80	8.53	2.85	8.89	2.89	9.20	2.94	9.65	2.98	9.87	3.02
	35	7.61	3.10	8.15	3.15	8.49	3.19	8.79	3.25	9.22	3.30	9.43	3.34
	41	7.20	3.32	7.71	3.37	8.04	3.42	8.32	3.48	8.72	3.53	8.92	3.57
46	6.73	3.51	7.21	3.57	7.51	3.61	7.77	3.68	8.15	3.73	8.34	3.78	

10. Capacity Table

Heat Pump

Combination Capacity Index (kBTu/h)	Outdoor Air Temp.: °CDB	Indoor Air Temp.: °CWB											
		14		16		18		19		22		24	
		TC kW	PI kW	TC kW	PI kW	TC kW	PI kW	TC kW	PI kW	TC kW	PI kW	TC kW	PI kW
9+9+12	21	8.39	2.22	8.98	2.26	9.36	2.29	9.69	2.33	10.16	2.37	10.39	2.40
	24	8.27	2.44	8.85	2.48	9.23	2.52	9.55	2.56	10.01	2.60	10.24	2.63
	29	7.97	2.80	8.53	2.85	8.89	2.89	9.20	2.94	9.65	2.98	9.87	3.02
	35	7.61	3.10	8.15	3.15	8.49	3.19	8.79	3.25	9.22	3.30	9.43	3.34
	41	7.20	3.32	7.71	3.37	8.04	3.42	8.32	3.48	8.72	3.53	8.92	3.57
	46	6.73	3.51	7.21	3.57	7.51	3.61	7.77	3.68	8.15	3.73	8.34	3.78
9+12+12	21	8.39	2.22	8.98	2.26	9.36	2.29	9.69	2.33	10.16	2.37	10.39	2.40
	24	8.27	2.44	8.85	2.48	9.23	2.52	9.55	2.56	10.01	2.60	10.24	2.63
	29	7.97	2.80	8.53	2.85	8.89	2.89	9.20	2.94	9.65	2.98	9.87	3.02
	35	7.61	3.10	8.15	3.15	8.49	3.19	8.79	3.25	9.22	3.30	9.43	3.34
	41	7.20	3.32	7.71	3.37	8.04	3.42	8.32	3.48	8.72	3.53	8.92	3.57
	46	6.73	3.51	7.21	3.57	7.51	3.61	7.77	3.68	8.15	3.73	8.34	3.78
7+7+7+7	21	8.39	2.22	8.98	2.26	9.36	2.29	9.69	2.33	10.16	2.37	10.39	2.40
	24	8.27	2.44	8.85	2.48	9.23	2.52	9.55	2.56	10.01	2.60	10.24	2.63
	29	7.97	2.80	8.53	2.85	8.89	2.89	9.20	2.94	9.65	2.98	9.87	3.02
	35	7.61	3.10	8.15	3.15	8.49	3.19	8.79	3.25	9.22	3.30	9.43	3.34
	41	7.20	3.32	7.71	3.37	8.04	3.42	8.32	3.48	8.72	3.53	8.92	3.57
	46	6.73	3.51	7.21	3.57	7.51	3.61	7.77	3.68	8.15	3.73	8.34	3.78
7+7+7+9	21	8.39	2.22	8.98	2.26	9.36	2.29	9.69	2.33	10.16	2.37	10.39	2.40
	24	8.27	2.44	8.85	2.48	9.23	2.52	9.55	2.56	10.01	2.60	10.24	2.63
	29	7.97	2.80	8.53	2.85	8.89	2.89	9.20	2.94	9.65	2.98	9.87	3.02
	35	7.61	3.10	8.15	3.15	8.49	3.19	8.79	3.25	9.22	3.30	9.43	3.34
	41	7.20	3.32	7.71	3.37	8.04	3.42	8.32	3.48	8.72	3.53	8.92	3.57
	46	6.73	3.51	7.21	3.57	7.51	3.61	7.77	3.68	8.15	3.73	8.34	3.78
7+7+7+12	21	8.39	2.22	8.98	2.26	9.36	2.29	9.69	2.33	10.16	2.37	10.39	2.40
	24	8.27	2.44	8.85	2.48	9.23	2.52	9.55	2.56	10.01	2.60	10.24	2.63
	29	7.97	2.80	8.53	2.85	8.89	2.89	9.20	2.94	9.65	2.98	9.87	3.02
	35	7.61	3.10	8.15	3.15	8.49	3.19	8.79	3.25	9.22	3.30	9.43	3.34
	41	7.20	3.32	7.71	3.37	8.04	3.42	8.32	3.48	8.72	3.53	8.92	3.57
	46	6.73	3.51	7.21	3.57	7.51	3.61	7.77	3.68	8.15	3.73	8.34	3.78
7+7+9+9	21	8.39	2.22	8.98	2.26	9.36	2.29	9.69	2.33	10.16	2.37	10.39	2.40
	24	8.27	2.44	8.85	2.48	9.23	2.52	9.55	2.56	10.01	2.60	10.24	2.63
	29	7.97	2.80	8.53	2.85	8.89	2.89	9.20	2.94	9.65	2.98	9.87	3.02
	35	7.61	3.10	8.15	3.15	8.49	3.19	8.79	3.25	9.22	3.30	9.43	3.34
	41	7.20	3.32	7.71	3.37	8.04	3.42	8.32	3.48	8.72	3.53	8.92	3.57
	46	6.73	3.51	7.21	3.57	7.51	3.61	7.77	3.68	8.15	3.73	8.34	3.78

Notes:

1. Capacities are based on the following conditions.
 Corresponding refrigerant piping length : 7.5m
 Level difference : 0m

2. TC : Total Capacity (kW)
 PI : Power Input (kW)

[Heating Capacity]

Combination Capacity Index (Capacity) (kBTu/h)	Indoor Air Temp.: °CDB	Outdoor Air Temp.: °CWB											
		-10		-5		0		6		10		15	
		TC kW	PI kW	TC kW	PI kW	TC kW	PI kW	TC kW	PI kW	TC kW	PI kW	TC kW	PI kW
7	16	1.98	0.96	2.33	1.04	2.70	1.14	3.14	1.23	3.39	1.29	3.75	1.38
	18	1.92	0.99	2.26	1.08	2.61	1.18	3.04	1.27	3.29	1.34	3.63	1.43
	20	1.86	1.02	2.19	1.11	2.53	1.21	2.93	1.31	3.19	1.38	3.52	1.48
	22	1.79	1.05	2.11	1.15	2.44	1.25	2.84	1.35	3.07	1.42	3.39	1.53
	24	1.73	1.08	2.04	1.19	2.36	1.29	2.74	1.39	2.97	1.47	3.28	1.57
9	16	2.18	0.96	2.56	1.04	2.97	1.14	3.45	1.23	3.73	1.29	4.12	1.38
	18	2.11	0.99	2.48	1.08	2.87	1.18	3.34	1.27	3.62	1.34	3.99	1.43
	20	2.04	1.02	2.41	1.11	2.79	1.21	3.22	1.31	3.51	1.38	3.87	1.48
	22	1.97	1.05	2.32	1.15	2.69	1.25	3.12	1.35	3.38	1.42	3.73	1.53
	24	1.90	1.08	2.24	1.19	2.59	1.29	3.02	1.39	3.27	1.47	3.60	1.57
12	16	2.37	0.96	2.80	1.04	3.24	1.14	3.76	1.23	4.07	1.29	4.50	1.38
	18	2.30	0.99	2.71	1.08	3.13	1.18	3.64	1.27	3.94	1.34	4.35	1.43
	20	2.23	1.02	2.63	1.11	3.04	1.21	3.51	1.31	3.83	1.38	4.22	1.48
	22	2.15	1.05	2.53	1.15	2.93	1.25	3.41	1.35	3.69	1.42	4.07	1.53
	24	2.08	1.08	2.45	1.19	2.83	1.29	3.29	1.39	3.56	1.47	3.93	1.57
18	16	3.56	1.49	4.20	1.63	4.85	1.78	5.64	1.92	6.11	2.02	6.74	2.17
	18	3.45	1.55	4.06	1.69	4.70	1.84	5.47	1.99	5.92	2.09	6.53	2.24
	20	3.35	1.60	3.94	1.74	4.56	1.90	5.27	2.05	5.74	2.16	6.34	2.31
	22	3.23	1.65	3.80	1.80	4.40	1.96	5.11	2.12	5.53	2.23	6.11	2.39
	24	3.11	1.70	3.67	1.86	4.25	2.02	4.94	2.18	5.34	2.30	5.90	2.46
24	16	5.22	2.45	6.15	2.68	7.12	2.92	8.28	3.15	8.96	3.32	9.89	3.55
	18	5.06	2.53	5.96	2.77	6.89	3.02	8.02	3.26	8.68	3.43	9.58	3.67
	20	4.91	2.62	5.78	2.86	6.69	3.11	7.73	3.36	8.42	3.54	9.29	3.79
	22	4.73	2.70	5.57	2.95	6.45	3.21	7.50	3.47	8.12	3.65	8.96	3.91
	24	4.57	2.78	5.38	3.04	6.23	3.31	7.24	3.58	7.84	3.77	8.65	4.03
7+7	16	3.48	1.49	4.10	1.63	4.75	1.78	5.52	1.92	5.97	2.02	6.59	2.17
	18	3.37	1.55	3.97	1.69	4.60	1.84	5.34	1.99	5.79	2.09	6.39	2.24
	20	3.27	1.60	3.85	1.74	4.46	1.90	5.16	2.05	5.61	2.16	6.20	2.31
	22	3.15	1.65	3.72	1.80	4.30	1.96	5.00	2.12	5.41	2.23	5.97	2.39
	24	3.05	1.70	3.59	1.86	4.15	2.02	4.83	2.18	5.22	2.30	5.77	2.46



10. Capacity Table

Heat Pump

Combination Capacity Index (kBtu/h)	Indoor Air Temp.: °CDB	Outdoor Air Temp.: °CWB											
		-10		-5		0		6		10		15	
		TC	PI	TC	PI	TC	PI	TC	PI	TC	PI	TC	PI
		kW	kW	kW	kW	kW	kW	kW	kW	kW	kW	kW	kW
7+9	16	3.68	1.49	4.34	1.63	5.02	1.78	5.83	1.92	6.31	2.02	6.97	2.17
	18	3.56	1.55	4.20	1.69	4.86	1.84	5.65	1.99	6.11	2.09	6.75	2.24
	20	3.46	1.60	4.07	1.74	4.71	1.90	5.45	2.05	5.93	2.16	6.55	2.31
	22	3.33	1.65	3.93	1.80	4.54	1.96	5.28	2.12	5.72	2.23	6.31	2.39
7+12	16	3.76	1.49	4.43	1.63	5.12	1.78	5.96	1.92	6.45	2.02	7.12	2.17
	18	3.64	1.55	4.29	1.69	4.96	1.84	5.77	1.99	6.25	2.09	6.89	2.24
	20	3.53	1.60	4.16	1.74	4.81	1.90	5.57	2.05	6.06	2.16	6.69	2.31
	22	3.40	1.65	4.01	1.80	4.64	1.96	5.40	2.12	5.84	2.23	6.45	2.39
7+18	16	3.29	1.70	3.87	1.86	4.48	2.02	5.21	2.18	5.64	2.30	6.23	2.46
	18	6.09	2.45	7.18	2.68	8.31	2.92	9.66	3.15	10.46	3.32	11.54	3.55
	20	5.90	2.53	6.95	2.77	8.04	3.02	9.35	3.26	10.12	3.43	11.18	3.67
	22	5.73	2.62	6.75	2.86	7.80	3.11	9.02	3.36	9.82	3.54	10.84	3.79
7+24	16	5.52	2.70	6.50	2.95	7.52	3.21	8.75	3.47	9.47	3.65	10.45	3.91
	18	5.33	2.78	6.28	3.04	7.26	3.31	8.45	3.58	9.14	3.77	10.09	4.03
	20	6.47	2.45	7.62	2.68	8.82	2.92	10.25	3.15	11.10	3.32	12.25	3.55
	22	6.27	2.53	7.38	2.77	8.54	3.02	9.93	3.26	10.75	3.43	11.87	3.67
9+9	16	6.08	2.62	7.16	2.86	8.29	3.11	9.58	3.36	10.43	3.54	11.51	3.79
	18	5.86	2.70	6.90	2.95	7.99	3.21	9.29	3.47	10.05	3.65	11.10	3.91
	20	5.66	2.78	6.67	3.04	7.71	3.31	8.97	3.58	9.71	3.77	10.72	4.03
	22	3.92	1.49	4.62	1.63	5.34	1.78	6.21	1.92	6.72	2.02	7.42	2.17
9+12	16	3.79	1.55	4.47	1.69	5.17	1.84	6.01	1.99	6.51	2.09	7.18	2.24
	18	3.68	1.60	4.34	1.74	5.02	1.90	5.80	2.05	6.31	2.16	6.97	2.31
	20	3.55	1.65	4.18	1.80	4.84	1.96	5.62	2.12	6.09	2.23	6.72	2.39
	22	3.43	1.70	4.04	1.86	4.67	2.02	5.43	2.18	5.88	2.30	6.49	2.46
9+18	16	5.44	2.45	6.41	2.68	7.42	2.92	8.62	3.15	9.34	3.32	10.30	3.55
	18	5.27	2.53	6.21	2.77	7.18	3.02	8.35	3.26	9.04	3.43	9.98	3.67
	20	5.11	2.62	6.02	2.86	6.97	3.11	8.06	3.36	8.77	3.54	9.68	3.79
	22	4.93	2.70	5.81	2.95	6.72	3.21	7.81	3.47	8.45	3.65	9.33	3.91
9+24	16	4.76	2.78	5.61	3.04	6.49	3.31	7.54	3.58	8.16	3.77	9.01	4.03
	18	6.09	2.45	7.18	2.68	8.31	2.92	9.66	3.15	10.46	3.32	11.54	3.55
	20	5.90	2.53	6.95	2.77	8.04	3.02	9.35	3.26	10.12	3.43	11.18	3.67
	22	5.73	2.62	6.75	2.86	7.80	3.11	9.02	3.36	9.82	3.54	10.84	3.79
12+12	16	5.52	2.70	6.50	2.95	7.52	3.21	8.75	3.47	9.47	3.65	10.45	3.91
	18	5.33	2.78	6.28	3.04	7.26	3.31	8.45	3.58	9.14	3.77	10.09	4.03
	20	6.53	2.45	7.69	2.68	8.90	2.92	10.35	3.15	11.20	3.32	12.37	3.55
	22	6.32	2.53	7.45	2.77	8.62	3.02	10.02	3.26	10.85	3.43	11.97	3.67
12+18	16	6.13	2.62	7.23	2.86	8.36	3.11	9.67	3.36	10.52	3.54	11.62	3.79
	18	5.91	2.70	6.97	2.95	8.06	3.21	9.37	3.47	10.14	3.65	11.20	3.91
	20	5.71	2.78	6.73	3.04	7.78	3.31	9.05	3.58	9.80	3.77	10.81	4.03
	22	5.52	2.86	6.49	3.11	7.52	3.31	8.75	3.65	9.47	3.84	10.45	4.10
7+7+7	16	6.53	2.45	7.69	2.68	8.90	2.92	10.35	3.15	11.20	3.32	12.37	3.55
	18	6.32	2.53	7.45	2.77	8.62	3.02	10.02	3.26	10.85	3.43	11.97	3.67
	20	6.13	2.62	7.23	2.86	8.36	3.11	9.67	3.36	10.52	3.54	11.62	3.79
	22	5.91	2.70	6.97	2.95	8.06	3.21	9.37	3.47	10.14	3.65	11.20	3.91
7+7+9	16	5.71	2.78	6.73	3.04	7.78	3.31	9.05	3.58	9.80	3.77	10.81	4.03
	18	5.88	2.45	6.92	2.68	8.01	2.92	9.31	3.15	10.08	3.32	11.13	3.55
	20	5.69	2.53	6.70	2.77	7.76	3.02	9.02	3.26	9.76	3.43	10.78	3.67
	22	5.52	2.62	6.50	2.86	7.53	3.11	8.70	3.36	9.47	3.54	10.46	3.79
7+7+12	16	5.32	2.70	6.27	2.95	7.25	3.21	8.44	3.47	9.13	3.65	10.08	3.91
	18	5.14	2.78	6.05	3.04	7.00	3.31	8.15	3.58	8.82	3.77	9.73	4.03
	20	6.31	2.45	7.44	2.68	8.60	2.92	10.00	3.15	10.83	3.32	11.95	3.55
	22	6.11	2.53	7.20	2.77	8.33	3.02	9.69	3.26	10.49	3.43	11.57	3.67
7+7+18	16	5.93	2.62	6.99	2.86	8.08	3.11	9.34	3.36	10.17	3.54	11.23	3.79
	18	5.72	2.70	6.73	2.95	7.79	3.21	9.06	3.47	9.81	3.65	10.82	3.91
	20	5.52	2.78	6.50	3.04	7.52	3.31	8.75	3.58	9.47	3.77	10.45	4.03
	22	5.33	2.86	6.28	3.11	7.26	3.31	8.45	3.65	9.14	3.84	10.09	4.10
7+9+9	16	6.51	2.45	7.67	2.68	8.87	2.92	10.32	3.15	11.17	3.32	12.33	3.55
	18	6.30	2.53	7.43	2.77	8.59	3.02	9.99	3.26	10.82	3.43	11.94	3.67
	20	6.12	2.62	7.21	2.86	8.34	3.11	9.64	3.36	10.49	3.54	11.58	3.79
	22	5.90	2.70	6.95	2.95	8.04	3.21	9.34	3.47	10.11	3.65	11.16	3.91
7+9+12	16	5.69	2.78	6.71	3.04	7.76	3.31	9.02	3.58	9.77	3.77	10.78	4.03
	18	6.31	2.45	7.44	2.68	8.60	2.92	10.00	3.15	10.83	3.32	11.95	3.55
	20	6.11	2.53	7.20	2.77	8.33	3.02	9.69	3.26	10.49	3.43	11.57	3.67
	22	5.93	2.62	6.99	2.86	8.08	3.11	9.34	3.36	10.17	3.54	11.23	3.79
7+9+18	16	5.72	2.70	6.73	2.95	7.79	3.21	9.06	3.47	9.81	3.65	10.82	3.91
	18	5.52	2.78	6.50	3.04	7.52	3.31	8.75	3.58	9.47	3.77	10.45	4.03
	20	6.71	2.45	8.10	2.68	9.40	2.92	10.80	3.15	11.80	3.32	13.10	3.55
	22	6.50	2.53	7.86	2.77	9.12	3.02	10.47	3.26	11.47	3.43	12.73	3.67

10. Capacity Table

Heat Pump

Combination Capacity Index (kBtu/h)	Indoor Air Temp.: °CDB	Outdoor Air Temp.: °CWB											
		-10		-5		0		6		10		15	
		TC kW	PI kW	TC kW	PI kW	TC kW	PI kW	TC kW	PI kW	TC kW	PI kW	TC kW	PI kW
7+9+12	16	6.29	2.45	7.41	2.68	8.58	2.92	9.97	3.15	10.80	3.32	11.92	3.55
	18	6.09	2.53	7.18	2.77	8.30	3.02	9.66	3.26	10.45	3.43	11.54	3.67
	20	5.91	2.62	6.96	2.86	8.06	3.11	9.31	3.36	10.14	3.54	11.19	3.79
	22	5.70	2.70	6.71	2.95	7.77	3.21	9.03	3.47	9.78	3.65	10.79	3.91
7+12+12	24	5.50	2.78	6.48	3.04	7.50	3.31	8.72	3.58	9.44	3.77	10.42	4.03
	16	6.51	2.45	7.67	2.68	8.87	2.92	10.32	3.15	11.17	3.32	12.33	3.55
	18	6.30	2.53	7.43	2.77	8.59	3.02	9.99	3.26	10.82	3.43	11.94	3.67
	20	6.12	2.62	7.21	2.86	8.34	3.11	9.64	3.36	10.49	3.54	11.58	3.79
9+9+9	22	5.90	2.70	6.95	2.95	8.04	3.21	9.34	3.47	10.11	3.65	11.16	3.91
	24	5.69	2.78	6.71	3.04	7.76	3.31	9.02	3.58	9.77	3.77	10.78	4.03
	16	6.53	2.45	7.69	2.68	8.90	2.92	10.35	3.15	11.20	3.32	12.37	3.55
	18	6.32	2.53	7.45	2.77	8.62	3.02	10.02	3.26	10.85	3.43	11.97	3.67
9+9+12	20	6.13	2.62	7.23	2.86	8.36	3.11	9.67	3.36	10.52	3.54	11.62	3.79
	22	5.91	2.70	6.97	2.95	8.06	3.21	9.37	3.47	10.14	3.65	11.20	3.91
	24	5.71	2.78	6.73	3.04	7.78	3.31	9.05	3.58	9.80	3.77	10.81	4.03
	16	6.53	2.45	7.69	2.68	8.90	2.92	10.35	3.15	11.20	3.32	12.37	3.55
9+12+12	18	6.32	2.53	7.45	2.77	8.62	3.02	10.02	3.26	10.85	3.43	11.97	3.67
	20	6.13	2.62	7.23	2.86	8.36	3.11	9.67	3.36	10.52	3.54	11.62	3.79
	22	5.91	2.70	6.97	2.95	8.06	3.21	9.37	3.47	10.14	3.65	11.20	3.91
	24	5.71	2.78	6.73	3.04	7.78	3.31	9.05	3.58	9.80	3.77	10.81	4.03
7+7+7+7	16	6.49	2.45	7.65	2.68	8.85	2.92	10.29	3.15	11.14	3.32	12.29	3.55
	18	6.28	2.53	7.40	2.77	8.57	3.02	9.96	3.26	10.78	3.43	11.90	3.67
	20	6.10	2.62	7.18	2.86	8.31	3.11	9.61	3.36	10.46	3.54	11.55	3.79
	22	5.88	2.70	6.92	2.95	8.01	3.21	9.32	3.47	10.08	3.65	11.13	3.91
7+7+7+9	24	5.68	2.78	6.69	3.04	7.74	3.31	9.00	3.58	9.74	3.77	10.75	4.03
	16	6.53	2.45	7.69	2.68	8.90	2.92	10.35	3.15	11.20	3.32	12.37	3.55
	18	6.32	2.53	7.45	2.77	8.62	3.02	10.02	3.26	10.85	3.43	11.97	3.67
	20	6.13	2.62	7.23	2.86	8.36	3.11	9.67	3.36	10.52	3.54	11.62	3.79
7+7+7+12	22	5.91	2.70	6.97	2.95	8.06	3.21	9.37	3.47	10.14	3.65	11.20	3.91
	24	5.71	2.78	6.73	3.04	7.78	3.31	9.05	3.58	9.80	3.77	10.81	4.03
	16	6.61	2.45	7.79	2.68	9.01	2.92	10.47	3.15	11.34	3.32	12.52	3.55
	18	6.40	2.53	7.54	2.77	8.72	3.02	10.14	3.26	10.98	3.43	12.12	3.67
7+7+9+9	20	6.21	2.62	7.31	2.86	8.46	3.11	9.78	3.36	10.65	3.54	11.76	3.79
	22	5.99	2.70	7.05	2.95	8.16	3.21	9.49	3.47	10.27	3.65	11.33	3.91
	24	5.78	2.78	6.81	3.04	7.88	3.31	9.16	3.58	9.92	3.77	10.94	4.03
	16	6.49	2.45	7.65	2.68	8.85	2.92	10.29	3.15	11.14	3.32	12.29	3.55
7+7+9+12	18	6.28	2.53	7.40	2.77	8.57	3.02	9.96	3.26	10.78	3.43	11.90	3.67
	20	6.10	2.62	7.18	2.86	8.31	3.11	9.61	3.36	10.46	3.54	11.55	3.79
	22	5.88	2.70	6.92	2.95	8.01	3.21	9.32	3.47	10.08	3.65	11.13	3.91
	24	5.68	2.78	6.69	3.04	7.74	3.31	9.00	3.58	9.74	3.77	10.75	4.03

Notes:

1. Capacities are based on the following conditions.
 Corresponding refrigerant piping length : 7.5m
 Level difference : 0m

2. TC : Total Capacity (kW)
 PI : Power Input (kW)



11. Operation Limits

Item	Range
Inlet air temperature (Cooling)	<p>Outdoor air temperature °C D.B.(°F)</p> <p>43(118.4)</p> <p>21(69.8)</p> <p>Standard operation</p> <p>15(59) 24(75.2)</p> <p>Indoor air temperature °C W.B.(°F)</p>
Inlet air temperature (Heating)	<p>Outdoor air temperature °C W.B.(°F)</p> <p>18(64.4)</p> <p>-7(14)</p> <p>Standard operation</p> <p>10(50) 24(75.2)</p> <p>Indoor air temperature °C D.B.(°F)</p>
Power source voltage	Rating $\pm 10\%$
Voltage at starting	Min. 85% of rating

12. Air Velocity and Temperature Distributions(Reference Data)

12.1 Wall Mounted Type

7k Btu/h Model

Cooling

Discharge angle:45°

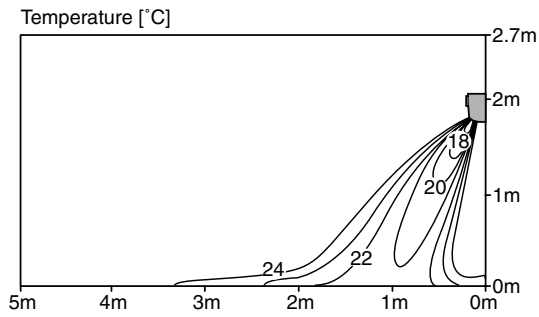
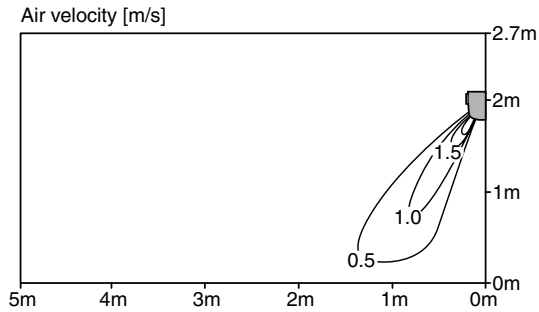

Heating

Discharge angle:50°

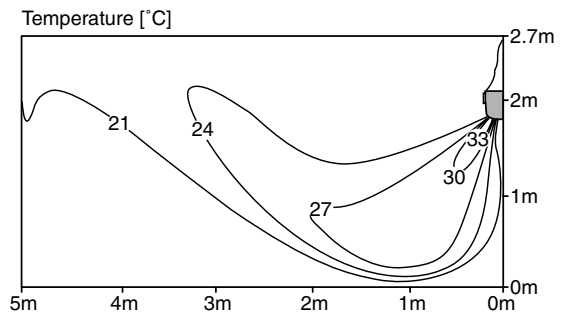
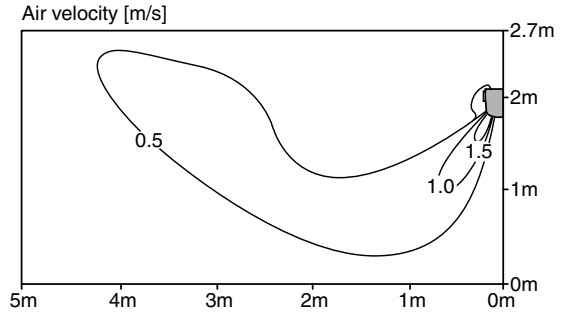

12.2 ART COOL Type

12k Btu/h Model

Cooling

Discharge angle:45°

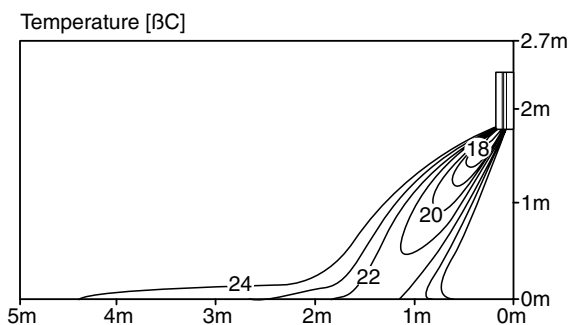
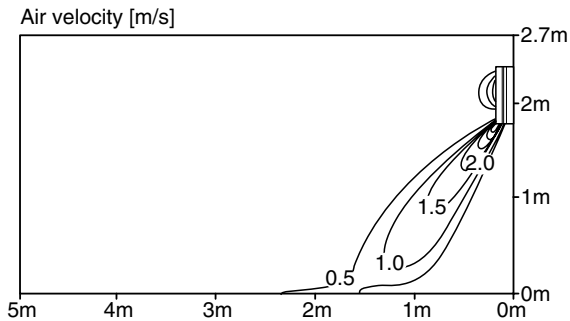

Heating

Discharge angle:50°

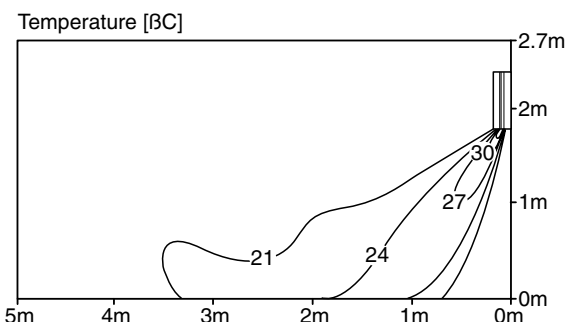
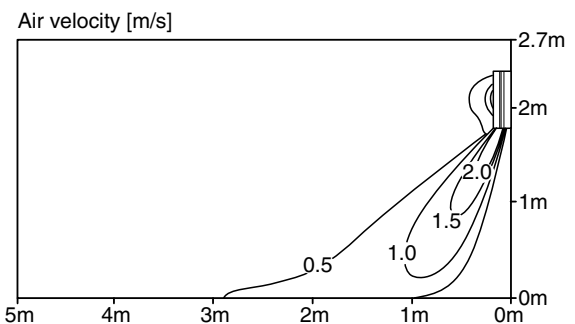



13. Sound Levels

13.1 Indoor Unit

Wall Mounted

Overall

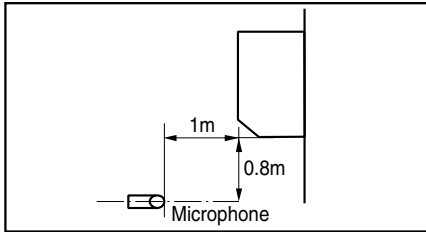

Notes:

- Sound measured at 1m away from the center of the unit.
- Data is valid at free field condition.
- Data is valid at nominal operation condition.
- Reference acoustic pressure 0dB=20μPa.
- Sound level will vary depending on a range of factors such as the construction(acoustic absorption coefficient) of particular room in which the equipment is installed.
- The operating conditions are assumed to be standard(KS conditions).

Model	Sound Levels(dBA)		
	H	M	L
AMNC/H076LQL0	34	31	28
AMNC/H096LQL0	35	32	30
AMNC/H126LRL0	38	36	34

Model	Sound Levels(dBA)		
	H	M	L
AMNC/H186LTLO	42	38	35
AMNC/H246LTLO	46	40	38

Sound Pressure Level

AMNC/H076LQL0

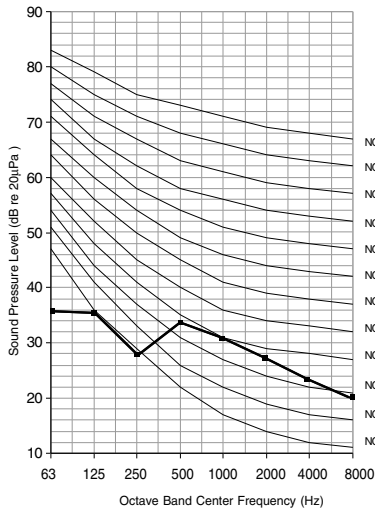

AMNC/H096LQL0

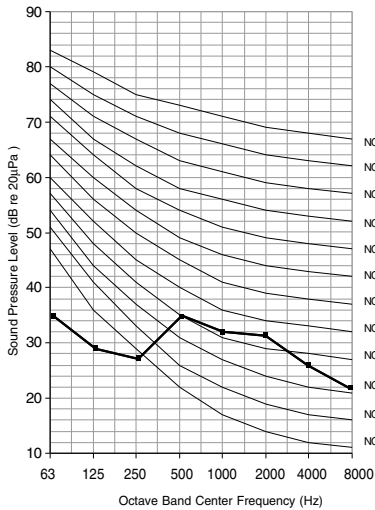

AMNC/H126LRL0

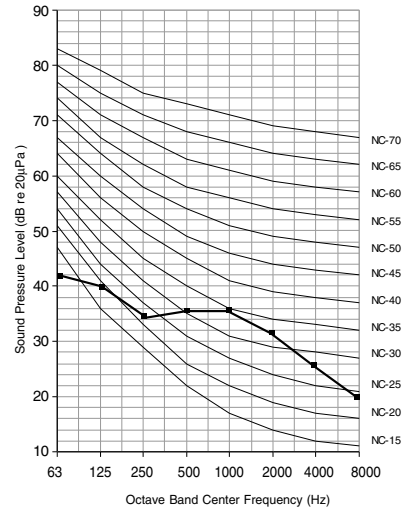

AMNC/H186LTLO

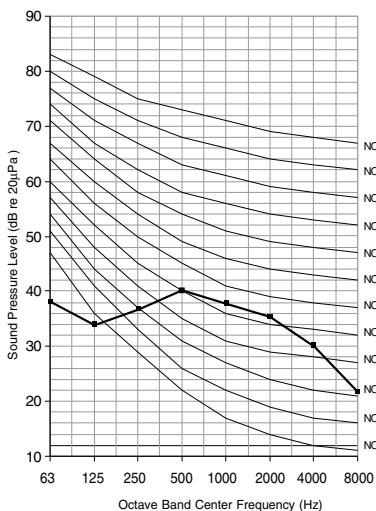

AMNC/H246LTLO

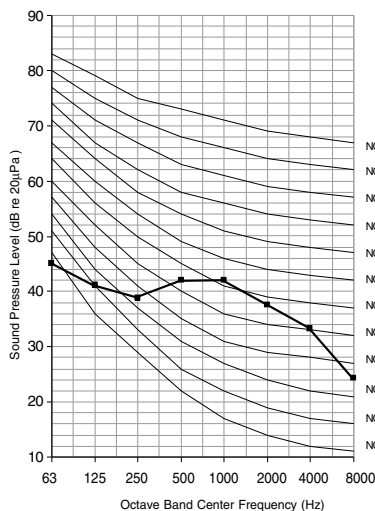

13. Sound Levels

ART COOL

Overall

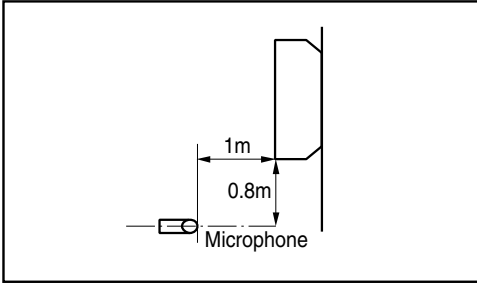

Notes:

- Sound measured at 1m away from the center of the unit.
- Data is valid at free field condition
- Data is valid at nominal operation condition
- Reference acoustic pressure $OdB = 20\mu Pa$
- Sound level will vary depending on a range of factors such as the construction (acoustic absorption coefficient) of particular room in which the equipment is installed.
- The operating conditions are assumed to be standard (KS conditions)

Model	Sound Levels (dBA)		
	H	M	L
AMNC/H096AP*1	37	31	27
AMNC/H126AP*1	43	39	31

Sound Pressure Level

AMNC/H096AP*1

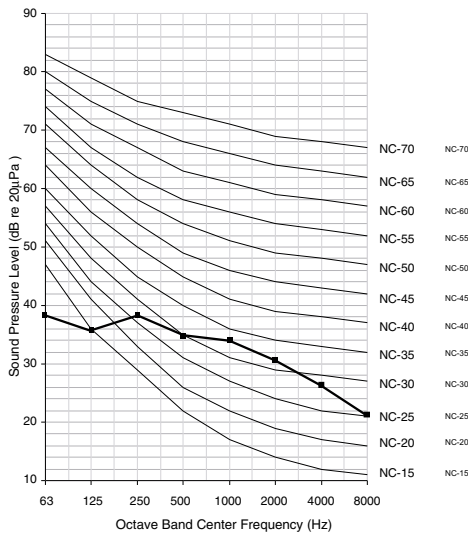

AMNC/H126AP*1

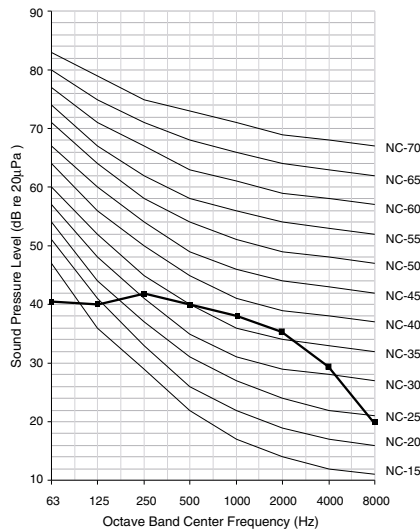



13. Sound Levels

13.2 Outdoor Unit Overall

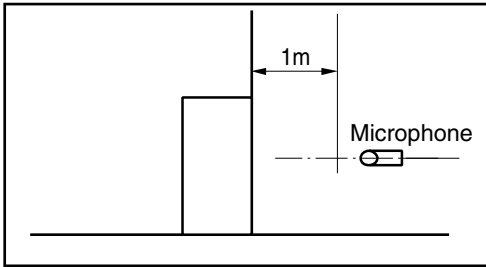

Notes:

- Sound measured at 1m away from the center of the unit.
- Data is valid at free field condition.
- Data is valid at nominal operation condition.
- Reference acoustic pressure 0dB=20μPa.
- Sound level will vary depending on a range of factors such as the construction(acoustic absorption coefficient) of particular room in which the equipment is installed.
- The operating conditions are assumed to be standard(KS conditions).

Model	50Hz, 220-240V
	Sound Pressure Levels(dBA)
A2UC/H146FA0	52
A2UC/H186FA0	53
A3UC/H216FA0	53
A4UC/H306FA0	54/51

Sound Pressure Level

A2UC/H146FA0

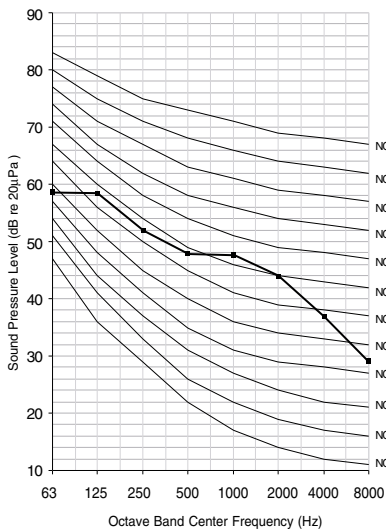

A2UC/H186FA0

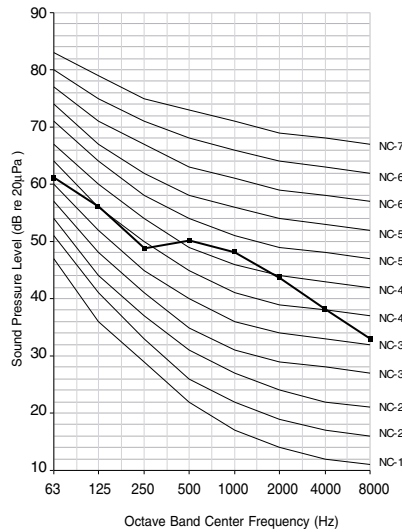

A3UC/H216FA0

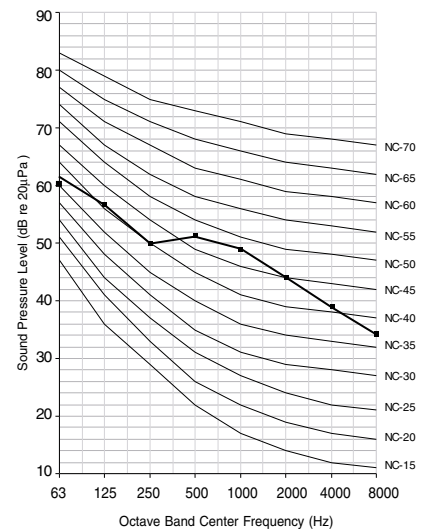

A4UC/H306FA0

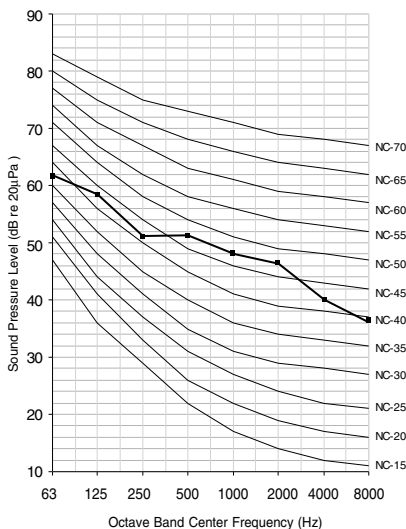

14. Installation

14.1 Piping Length & Refrigerant Charge

The maximum allowable level and piping length

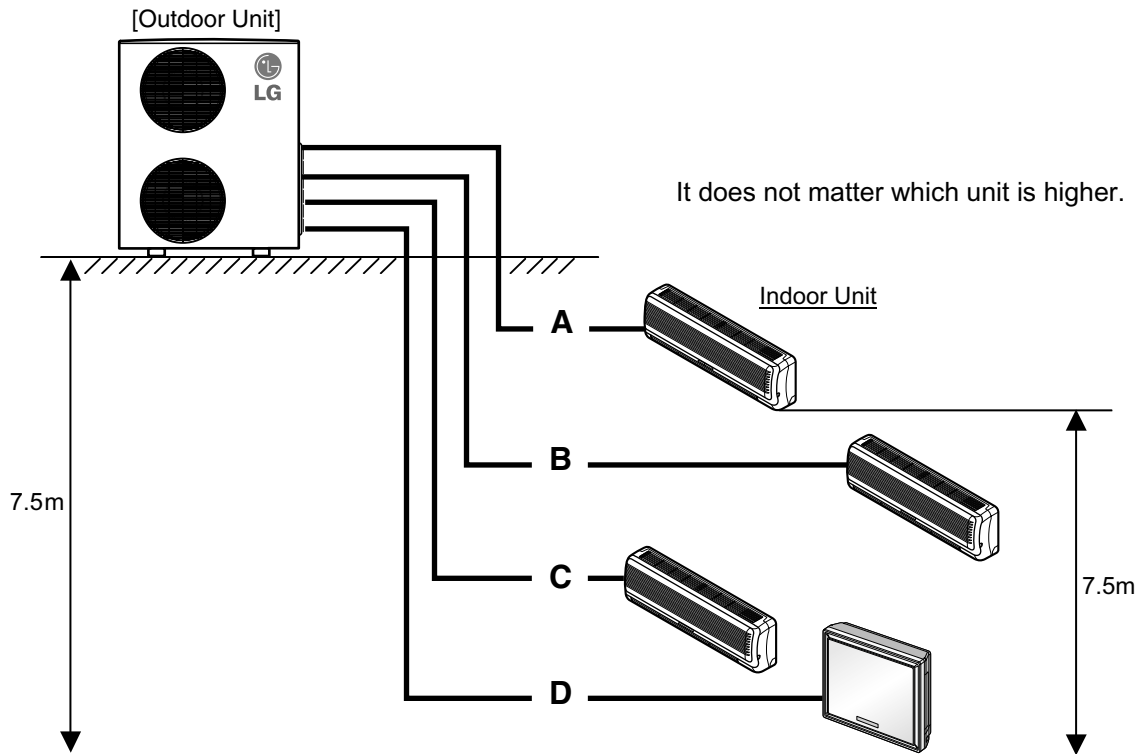

Model [Outdoor Unit]	Standard Length	Max piping length each indoor unit				Max total piping length
	A, B, C, D	A	B	C	D	
A2UC/H146FA0	7.5m	15m	15m	-	-	30m(A+B)
A2UC/H186FA0	7.5m	15m	15m	-	-	30m(A+B)
A3UC/H216FA0	7.5m	15m	15m	15m	-	45m(A+B+C)
A4UC/H306FA0	7.5m	15m	15m	15m	15m	60m(A+B+C+D)

Refrigerant Charge

Indoor Unit Capacity (Btu/h)	Pipe Size		Rated Length	Max Length	Additional Refrigerant
	Gas	Liquid			
7k, 9k, 12k	3/8"(9.52mm)	1/4"(6.35mm)	7.5m	15m	30g/m
18k, 24k	1/2"(12.7mm)	1/4"(6.35mm)	7.5m	15m	30g/m

* Extra refrigerant = (Extended length - Rated length) x Additional refrigerant



14. Installation

14.2 Select the best location

14.2.1 Indoor Unit

Install the air conditioner in the location that satisfies the following conditions.

Wall Mounted Type

- There should not be any heat source or steam near the unit.
- There should not be any obstacles to prevent the air circulation.
- There should be easy provision of condensate drain age.
- Taking into account the noise prevention criteria, spot the installation location
- Do not install the unit near the door way.
- Keep proper distance from ceiling, fence floor, walls & other obstacles as shown in figure.

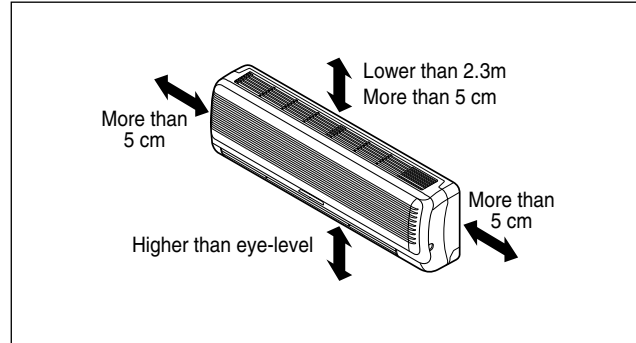

ART COOL Type

- Do not have any heat or steam near the unit.
- Select a place where there are no obstacles in front of the unit.
- Make sure that condensation drainage can be conveniently routed away.
Do not install near a doorway.
- Ensure that the space around the left and right of the unit is more than 50cm. The unit should be installed as high on the wall as possible, allowing a minimum of 10cm from ceiling.
- Use a stud finder to locate studs to prevent unnecessary damage to the wall.

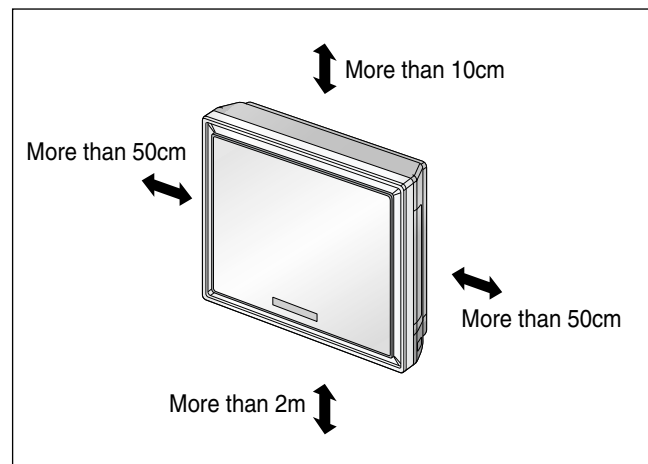

14. Installation

14.2.2 Outdoor Unit

- If an awning or canopy is built over the unit to prevent direct sunlight or rain exposure, make sure that heat radiation from the condenser is not restricted.
- Ensure that the space around the back is more than 20~30cm and sides is more than 20~30cm. The front of the unit should have more than 70cm of space.
- Do not place animals and plants in the path of the warm air.
- Take the air conditioner weight into account and select a place where noise and vibration are minimum.
- Select a place so that the warm air and noise from the air conditioner do not disturb neighbors.
- Rooftop Installations : If the outdoor unit is installed on a roof structure, be sure to level the unit. Ensure the roof structure and anchoring method are adequate for the unit location. Consult local codes regarding rooftop mounting.

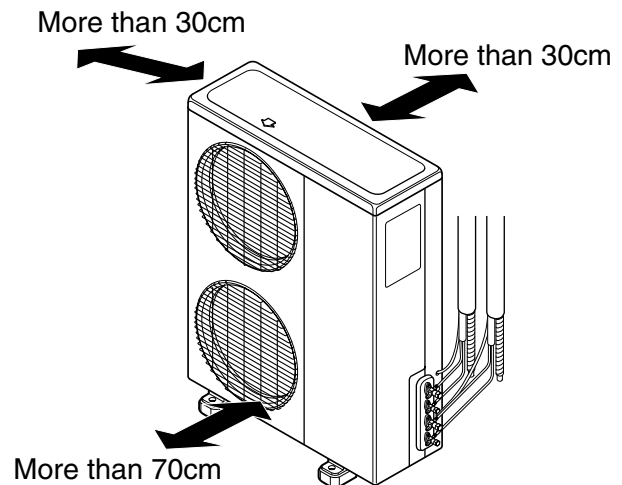
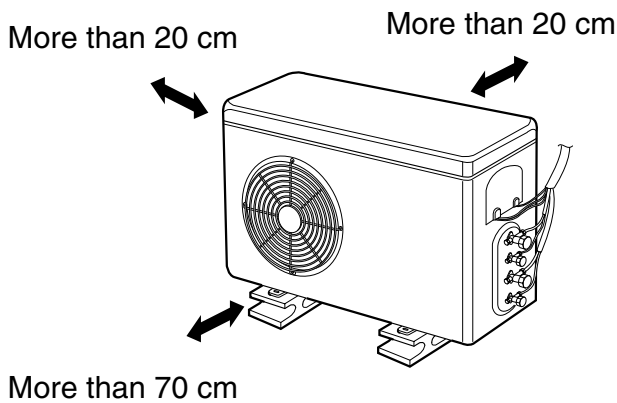

14.3 Settlement of outdoor unit

- Anchor the outdoor unit with a bolt and nut($\phi 10\text{mm}$) tightly and secure it horizontally on a concrete or rigid mount.
- When installing on the wall, roof or rooftop, anchor the mounting base securely with a nail or wire assuming the influence of wind and earthquake.
- In the case when the vibration of the unit is conveyed to the hose, secure the unit with an anti-vibration rubber.

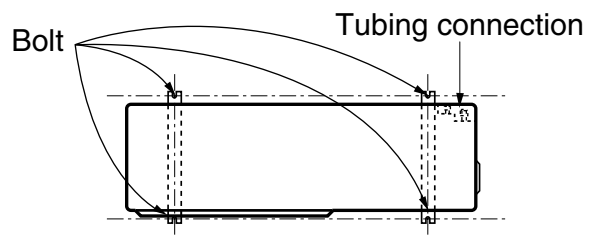



14. Installation

14.4 Connecting Pipings and the cable to Outdoor unit

14.4.1 Connecting the pipings to the Outdoor unit

1. While installing pipes, you must use the connector.

2. Align the center of the pipings and tighten the flare nut by hand

Indoor Units	Gas		Liquid	
	A	B	A	B
18k, 24k	Ø9.52→Ø12.7		Not necessary	

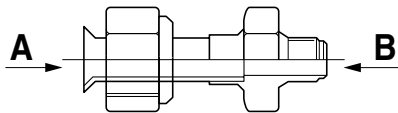
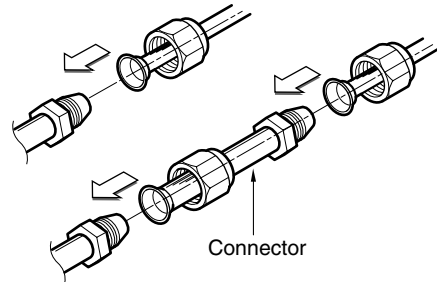

3. Finally, tighten the flare nut with torque wrench until the wrench clicks.

■ When tightening the flare nut with torque wrench, ensure the direction for tightening follows the arrow on the wrench.

*Connecting pipe size

Indoor Units	Gas side	Liquid side
7k	Ø9.52(3/8)	Ø6.35(1/4)
9k	Ø9.52(3/8)	Ø6.35(1/4)
12k	Ø9.52(3/8)	Ø6.35(1/4)
18k	Ø12.7(1/2)	Ø6.35(1/4)
24k	Ø12.7(1/2)	Ø6.35(1/4)

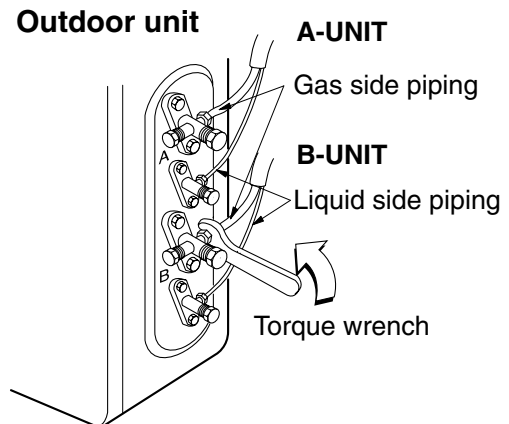

14.4.2 Connect the cable

Connecting the cable to the Indoor unit.

Connect the cable to the indoor unit by connecting the wires to the terminals on the control board individually according to the outdoor unit connection. (Ensure that the color of the wires of the outdoor unit and the terminal No. are the same as those of the indoor unit.)

The earth wire should be longer than the common wires.

The circuit diagram is not subject to change without notice.

When installing, refer to the circuit diagram of indoor & outdoor unit. Indoor connection circuit is behind the front panel & outdoor connection circuit is inside the control cover.



CAUTION:

- The circuit diagram is not subject to change without notice.
- Be sure to connect wires according to the wiring diagram.
- Connect the wires firmly, so that not to be pulled out easily.
- Connect the wires according to color codes as referred in the wiring diagram.

14. Installation



CAUTION: Provide a circuit breaker between power source and the unit as shown below.

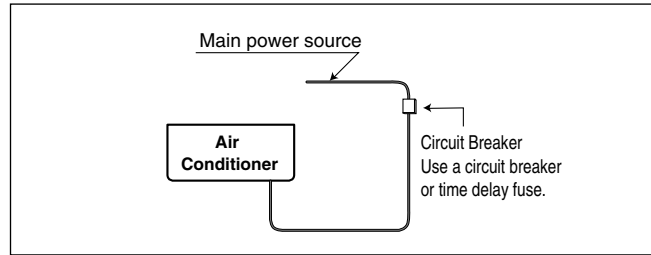

CAUTION: The power cord connected to the outdoor unit should be complied with the following specifications (Cable type approved by HAR or SAA).

NORMAL CROSS SECTIONAL AREA	Grade (mm ²)			
	18k	24k	30k	40k
	2.5	2.5	3.5	5.5
Cable Type	H05RN-F	H05RN-F	H05RN-F	H05RN-F

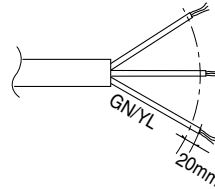

The power connecting cable connected to the indoor and outdoor unit should be complied with the following specifications (Type "B" approved by HAR or SAA).

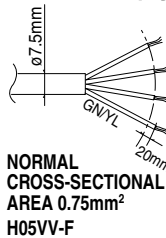

Connecting the cable to the Outdoor unit.

1. Remove the control cover from the unit by loosening the screw.
Connect the wires to the terminals on the control board individually as the following.
2. Secure the cable onto the control board with the holder (clammer).
3. Refix the control cover to the original position with the screw.
4. Use a recognized circuit breaker between the power source and the unit. A disconnection device to adequately disconnect all supply lines must be fitted.

Circuit Breaker (A)	Grade (Btu/h)		
	14k	18k/21k	30k
	15	20	30

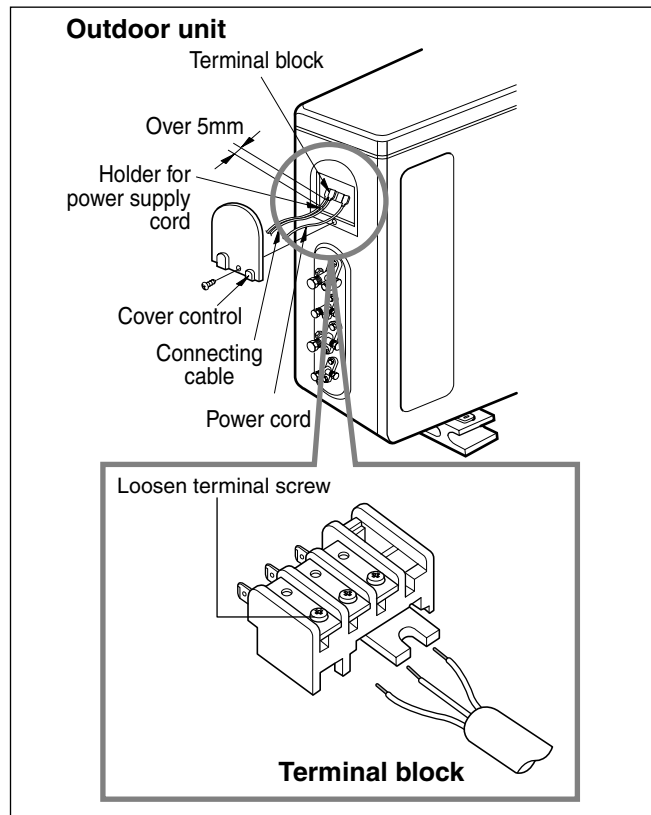



14. Installation



CAUTION

After the confirmation of the above conditions, prepare the wiring as follows.

1. Never fail to have an individual power circuit specifically for the air conditioner. For wiring, method take guidance from the circuit diagram posted on the inside of control cover.
2. Firmly tighten the terminal screws to prevent them loosening. After tightening, pull the wires lightly to confirm that they do not move. (If they are loose the unit will not operate normally or it can cause burn-out of the wires.)
3. Check specification of power source.
4. Confirm that electrical capacity is sufficient.
5. See to that the starting voltage is maintained at more than 90 percent of the rated voltage marked on the name plate.
6. Confirm that the cable thickness is as specified in the power source specification.
(Particularly note the relation between cable length and thickness.)
7. An earth leakage circuit breaker should be equipped in a wet or moist area.
8. The following would be caused by voltage drop.
 - Vibration of a magnetic switch, which will damage the contact point, fuse breaking, disturbance of the normal function of the overload.
9. The means for disconnection from a power supply shall be incorporated in the fixed wiring and have an air gap contact separation of at least 3mm in each active(phase) conductors.

14. Installation

14.5 Drain Pipe Work

□ Drain pipe gradient and support

- 1) - The drain pipe must be fitted at a gradient of at least 1/100.
- The drain pipe should be as short as possible and free from airlocks.

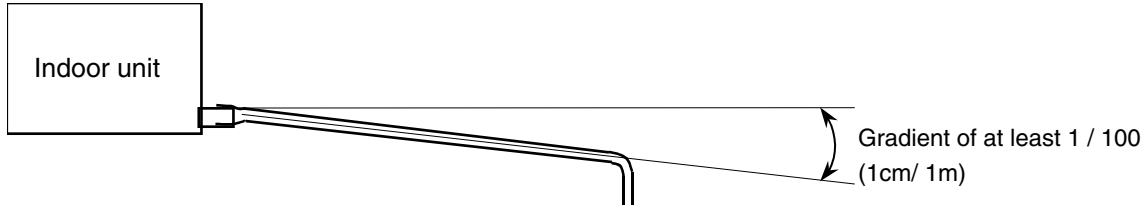

- 2) Suspension bolts should be used to support long stretches of drain pipe in order to ensure that a gradient of 1/100 is maintained.(PVC pipe should not be bent)

Spacing of supports for horizontal piping

Class	Nominal diameter	Spacing
Rigid PVC pipe	25~40mm	1.0m or less

- 3) The length of pipe laid horizontally should be kept a minimum.

□ Drain trap

Fit any indoor unit whose drain pipe connection is subjected to negative pressure, with a drain trap.

- 1) Rig the drain trap as shown in the drawing below

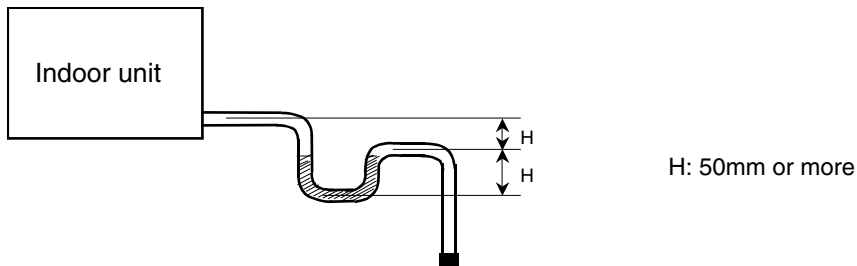

- 2) Provide one trap per unit. A single trap for converging units will prove ineffective.
- 3) Rig the trap to allow for future changing.

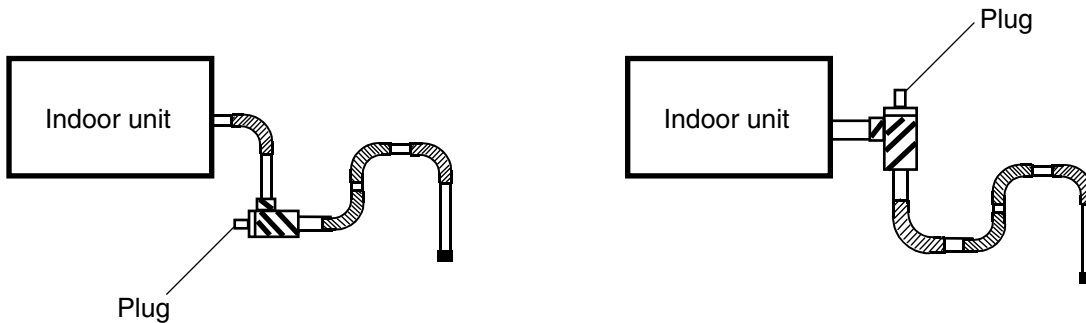



15. Function of Remote Controller

15.1 Wireless LCD Remote Controller

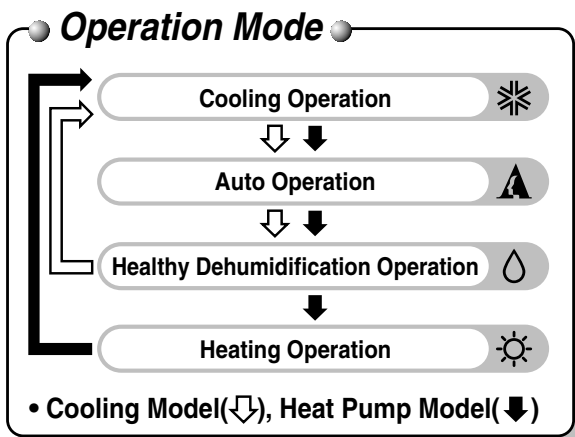
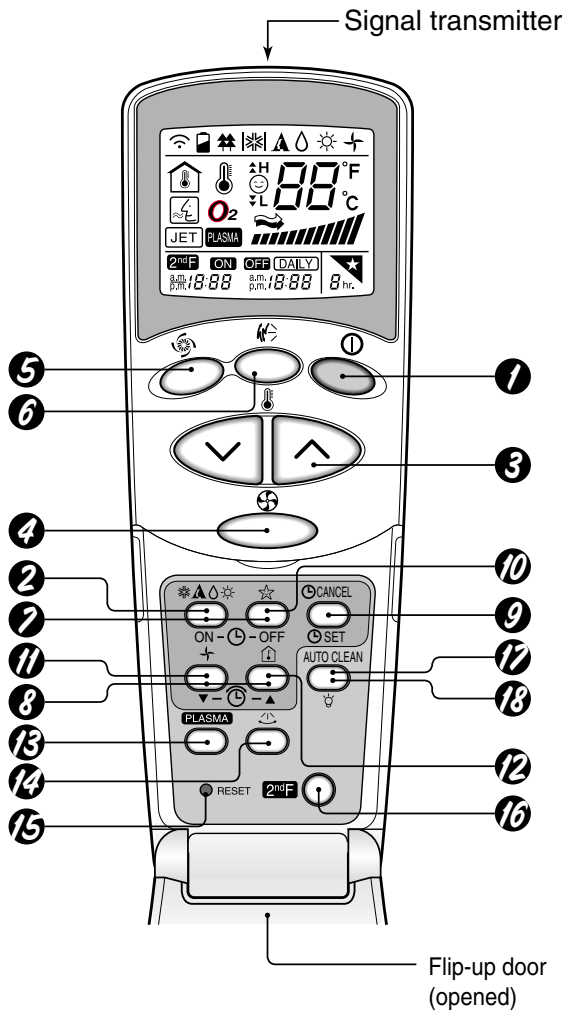

- 1 START/STOP BUTTON**
Operation starts when this button is pressed and stops when the button is pressed again.
- 2 OPERATION MODE SELECTION BUTTON**
Used to select the operation mode.
- 3 ROOM TEMPERATURE SETTING BUTTONS**
Used to select the room temperature.
- 4 INDOOR FAN SPEED SELECTOR**
Used to select fan speed in four steps low, medium, high and CHAOS.
- 5 JET COOL**
Used to start or stop the speed cooling. (Speed cooling operates super high fan speed in cooling mode.)
- 6 CHAOS SWING BUTTON**
Used to stop or start louver movement and set the desired up/down airflow direction.
- 7 ON/OFF TIMER BUTTONS**
Used to set the time of starting and stopping operation.
- 8 TIME SETTING BUTTONS**
Used to adjust the time.
- 9 TIMER SET/CANCEL BUTTON**
Used to set the timer when the desired time is obtained and to cancel the Timer operation.
- 10 SLEEP MODE AUTO BUTTON**
Used to set Sleep Mode Auto operation.
- 11 AIR CIRCULATION BUTTON**
Used to circulate the room air without cooling or heating.
- 12 ROOM TEMPERATURE CHECKING BUTTON**
Used to check the room temperature.
- 13 PLASMA(OPTIONAL)**
Used to start or stop the plasma-purification function.
- 14 HORIZONTAL AIRFLOW DIRECTION CONTROL BUTTON (NOT ON ALL MODELS)**
Used to set the desired horizontal airflow direction.
- 15 RESET BUTTON**
Used prior to resetting time or after replacing batteries.
- 16 2nd F Button**
Used prior to using modes printed in blue at the bottom of buttons.
- 17 AUTO CLEAN**
Used to set Auto Clean mode.
- 18 LED LUMINOSITY**
Used to adjust LED luminosity.

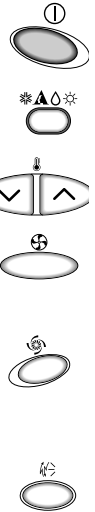



LG Electronics Inc.

20 Yoido-dong, Youngdungpo-gu, Yoido P.O.Box 355
Seoul 150-721, Korea

Phone: 3777-7969 Fax: 3777-5137/8

<http://www.lge.com>

<http://biz.lgservice.com>

P/No.: 3828A20428F



For continual product development, LG reserves the right to change specifications without notice
©LG Electronics INC. Printed in Korea. December/2003